

2022

Press Pack

Our fasteners enable innovation
today to build a better tomorrow





Trifast invests to increase its European manufacturing capacity



International fastener specialist TR VIC spa, part of the Trifast plc group of companies, has once again benefited from a significant investment at its manufacturing site in central Italy.

In expanding the TR Viterie Italia Centrale (TR VIC spa) site in Fossato Di Vico in Umbria, Trifast is further increasing its capacity to meet the growing European white goods market. They have experienced unprecedented demand, which has been fuelled by the increase in consumer driven home improvements during Covid that shows no signs of abating.

The investment is largely focused on securing new machinery at the site, all locally sourced from Italian manufacturers, and this will increase the production capacity by some 33%. It builds on an earlier move back in January 2021 to implement additional multi-station cold forming machinery in their heading section. This will result in their ability to produce an additional 500 million pieces annually over the next 12 months.

The site is focussed on being 'Industry 4.0 compliant' creating a greener and more efficient workspace, providing a modern, fresh and diverse environment. The work is to be completed in two phases in 2022 and 2023 which includes extending the manufacturing footprint on the site.

Andrew Nuttall, European Managing Director of TR Fastenings, said: "The order book has increased dramatically over the past two years. As

more people work from home, they are investing in their domestic appliances and not spending so much on holidays etc and instead enhancing their home environment. This means that the demand for white goods has significantly increased. Our major customers want to see shorter and more agile supply chains. The lead times out of Asia have increased significantly during Covid and freight costs and container issues has meant that we had to react and onshore more product. This investment strategy allows us to better meet our customer needs, now and for the future."

Stefano Pisoni, Managing Director of TR VIC Spa, said: "This investment represents a huge step forwards for our capability to meet growing demand. The site was operating at 130% of its capacity putting a strain on the workforce to meet customers' demands. We are now embarking on the first steps, not only to futureproof our group against supply chain disruption, but also to ensure we continue to meet the demands of our customers. In sharing this news with them at every opportunity the feedback has been fantastic that we have instigated this investment.

The investment has been well received locally, creating new jobs and this has piqued the interest with local Government and the Media giving us the recognition that we are an important manufacturing company in this key area of Italy. We are proud of the fact that we have chosen Italian companies to supply the new machinery."





Trifast invests to increase its European manufacturing capacity

Continued



Glenda Roberts, Global Projects and Marketing Director of Trifast plc, added: *“We are very confident in our ongoing programme of investment in Italy. This move has come directly from customers telling us they want us to manufacture in Europe, nearer to market, and avoiding the supply chain challenges that have been hampering the sector. More widely, this is how things are going. Major brands want this. This will become a growing part of the TR strategy future proofing against supply chain disruption and investing in the European manufacturing economy.”*

The TR VIC site serves 24 countries around the world and the site will also have capacity to serve more [Health & Home](#) and [Light & Heavy Vehicle](#) sectors.

TR VIC is a member of the [European Fastener Distributor Association \(EFDA\)](#) and has [IATF 16949](#) accreditation.





Electric vehicles are fuelling market demand for plastic components



By Andrew Fletcher, Director of Plastics & Rubber (Commercial & Technical), TR Fastenings Ltd.

Credit: British Plastics & Rubber magazine

As the global momentum of EV production continues at pace, automotive manufacturers are increasingly turning to alternative component materials to help improve the overall efficiency of electric vehicles.

With government regulations on vehicle emissions, a key driver for EV growth, most automotive manufacturers are now looking at using plastics as base materials to build automotive parts.

Plastics and composites have been used in vehicles for decades, mainly due to their lightweight properties which can be 30% to 50% less compared to metal. Today, lightweight plastics can make up 50% of a vehicle's volume, but only 10% of its weight. Therefore, it is a natural development that plastic components are being incorporated into electric and hybrid vehicles. This helps to help offset the weight of electric motors and battery housings, and provides the performance and efficiency.

The perfect material for design teams

There are further benefits with plastic components including their exceptional electrical and thermal insulation qualities, and its resistance to corrosion. For those in the design field, plastic remains an extremely flexible material, one that can

be incorporated into even the most complex components with relative ease and freedom. And for high volume production, an important factor as EV production continues to increase, it's possible to remain pleasingly cost-effective.

In addition, it's worth noting that the more common plastic components can not only be produced in high quantities, they can also be manufactured more cost effectively, benefit from shorter lead times and are less wasteful. Metal components, which have been widely used in car manufacture, are generally unable to offer such benefits. This leads to them becoming more marginalised in the automotive industry in general, and the EV sector in particular.

The advantages of plastic components will of course inevitably be accompanied by challenges, but these are becoming more inconsequential. For example, plastic is limited in its torsional stiffness, as well as its impact and punch resistance. There are heat resistance and flammability issues that also need to be considered. A hurdle the industry is acutely aware of is achieving the necessary levels of trust in the materials in order to change design practices towards using non-metallic materials. Overall, however, concerns around using plastic are outweighed by the various advantages that it can clearly offer.

Application versatility

Currently, the most common plastic applications





Electric vehicles are fuelling market demand for plastic components

Continued



in EV's include instrument panels, module housings, breakers and switches, battery trays, trim fasteners, cooling system components and crash protection systems. Given the flexibility of plastic as a manufacturing material, and of course its lightness, it's understandable that designers are incorporating plastic even more frequently now.

In certain applications, metal components can be incorporated into plastic mouldings to help achieve the required structural performance. Compression Limiters are a good example of this. They are used extensively in composites and plastic mouldings as through holes to help reduce the stress generated by conventional fasteners. Traditional threaded fasteners can generate a great deal of compressive stress during their everyday use, but metal Compression Limiters can protect against damage without compromising on the integrity of the materials involved. Demand for Compression Limiters has mainly been driven by the automotive sector.

The drive towards energy efficiency

Going forwards, it's easy to imagine plastic components, their mountings and their housings all taking on an even more crucial role in the design of electric vehicles. Battery ranges between charges are already important, of course, and they will need to continue to improve. Keeping vehicles on the lighter side, perhaps with increased usage of reinforcing materials such as glass and carbon fibre, will inevitably lead to further gains in the

drive towards energy efficiency levels that were previously thought unachievable.

One of the challenges facing our design team has been the need for components that are capable of maintaining maximum performance under stress. The integrity of bends and joints under the most intense pressure is a must in EVs, and that remains a high priority for product developers and designers. TR Fastenings has been actively involved in component development in recent years, and will continue to work closely with manufacturers on products designed to dovetail perfectly with their need for innovation.

The EV market has seen rapid growth in recent years with a drive to improve and protect our environment. These are exciting times for the automotive sector, and the changing sustainability demands requires us to be more innovative in our thinking and designs.





TR debuts next generation website with more content and functionality than ever before

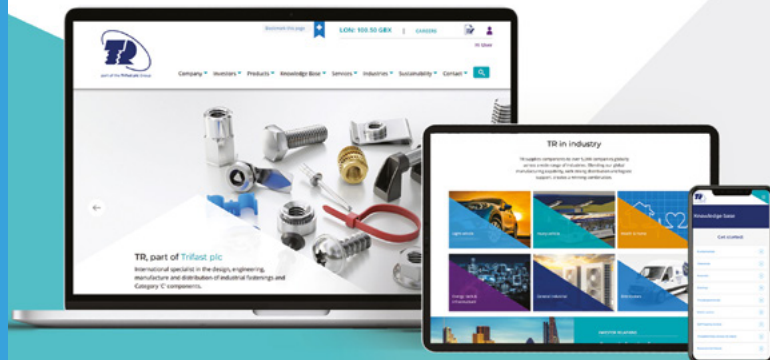

TR Fastenings Ltd (TR), part of the Trifast plc group is proud to announce the launch of a brand-new enriched content led website designed for the evolving global marketplace. This new interactive site which is packed with enhancements throughout, showcases the capabilities across the Group whilst providing one of the best online experience within the industry.

This latest investment by TR welcomes a consolidation of the investor site www.trifast.com and the corporate site into one new focused website www.trfastenings.com. Moving to a single, digital front door allows TR to engage its investors, customers and the marketplace as a unified global company.

The new TR website at a glance

There are a number of highly impressive new features incorporated into the site. TR has introduced enhanced content, including the product library and knowledge base which will be of particular interest to the engineering and design community providing the latest user guides, product and sector animations and a new range of fully interactive 3D models.

A unique bookmarking feature has also been introduced which will effectively allow a user to save pages of interest. This creates a personalised area that's unique to them which can be quickly referenced and shared with colleagues.

Interactive Smart City animations

Key to the user experience for designers and engineers is the innovative use of the interactive TR Smart City animation within the media library and industry sections. These will help end users to envisage how TR's components can be incorporated into new and existing designs.

[TR media library](#)

3D models enhance usability for designers and engineers

TR provides products to a wide range of industry sectors. 2D and 3D models are embedded within the product pages to give a clearer indication of how they can be utilised. Our library of parts provides an enhanced level of usability for designers, engineers and specifiers.

[Products](#)

New investor tools

The investor information provides a holistic view of the Company with features including interactive investor analysis tools for key financials and sustainability, a TSR (Total Shareholder Return) tool, a financial calendar, a Regulatory News Service and all of the latest Analyst Reports with an equity research tool.

[TR Investors](#)

The enhanced design truly reflects the multiple





TR debuts next generation website with more content and functionality than ever before

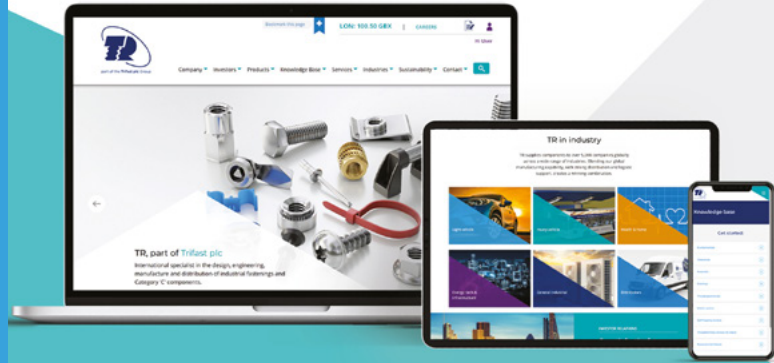

markets that TR services encompassing all key disciplines. Purchasing and technical specialists have been regular users of TR's website, but this has widened and now attracts those working in the quality, environmental, HR and financial sectors. It's a changing world, and the new site reflects this perfectly.

Glenda Roberts, Global Projects and Marketing Director commented; *"As of today we receive over 5 million page views on our website annually and content is king. Therefore, we took the opportunity 9 months ago to completely revamp the website. The objective was to enhance the user guest experience with enriched content designed to appeal to a much wider audience of differing disciplines. I am very proud of what we have achieved in house as a team with the support of an excellent design house, Tiga Creative Marketing."*





TR Fastenings launch a range of compression limiters 2022

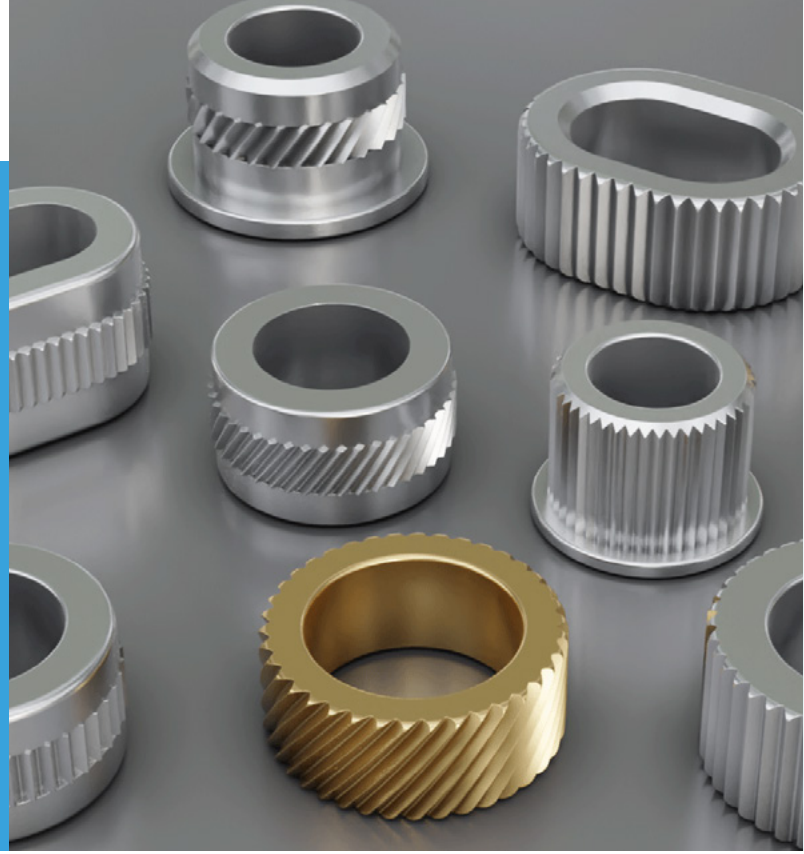

As the speed of technology and trends in consumer behaviour accelerates, companies around the world are evolving quickly and TR Fastenings is no exception. TR's latest product launch of Compression Limiters has been developed to meet the growing global demand from multi-sector manufacturers developing products using plastics, particularly in the EV space.

Compression Limiters reduce the stress that's generated by traditional threaded fasteners. Demand has mainly been driven by the automotive sector, and applications in the energy and general industrial sectors where high load bearing plastic components are used and have also contributed to the surge in worldwide demand.

Growth in automotive component demand:

Compression Limiters are used extensively in composites and plastic mouldings as through holes help reduce the stress generated by conventional fasteners. These non-threaded inserts are commonly used in applications where a compressive load is applied to a plastic assembly to prevent the integrity of the plastic being compromised.

These products are used extensively in electric vehicles and the battery housings. As technological advances continue, so does the need to continually develop the primary components that make up an electric vehicle. Newly created giga factories and battery housings manufacturers in Europe, Asia and North America will be looking to include these products in many upcoming automotive research and development projects and with a global presence, TR Fastenings is ideally positioned to

meet this demand, whilst also providing technical and design assistance.

The product range

TR's experience over the last few years is that many of these are designed in specials and required in high volume. There are a number of different types and as a guide the TR's Compression Limiter range consists of symmetrical, flanged, split seam and oval manufactured from steel, stainless, brass and aluminium.

Net-zero

As we head towards 2030 and net-zero, there will be greater technical requirements from the automotive industry as it continues to boom. The need for joint strength and integrity will remain a critical requirement as manufacturers work flat out to launch new zero-emission electric vehicle models.

Although the fundamental technologies behind electric vehicles have been around for years, it's only recently that these have come together to produce the EV's that are now available. As changes in mobility are changing the industry at pace, component manufacturers such as TR are leading the way in the design, development and supply of fasteners for plastic.





Words matter by Dan Jack, Global Sales and Commercial Director



I am sure that there was a period in the last two years when a count was kept on how many times the word unprecedented would be used in a week. That filter quickly narrowed down to daily usage and latterly into just one meeting or even a report. It seems the use of the adjective is indeed unprecedented!

Adjectives tethered to these times and occasions include agile, resilient, adaptable, flexible and supple. Strategic documents, board meetings, emergency and mandatory reviews are all garnished with a vocabulary that expresses a collective determination to survive or thrive.

In our industry of fasteners (fastening, noun, a device that secures something) the pressures of raw material and freight costs, lead times, anti-dumping duties, microchip shortages, labour availability, legislation and compliance, disrupted supply chains and rising energy costs all converge.

This convergence is met head on by major changes in technology combined with, and partly driven by, a concerted political will to see skies brighter, air cleaner and humanity healthier in all its forms.

Seminal, by definition, is not a frequently used word and typically is a judgement based on looking to the past.

At this juncture in time it is hard to believe that these frenetic activity levels combined with the

pace and scale of change, leaving many firms in our industry gasping for breath and asking “what next?”, can be described as anything other than seminal.

There is no immunity here at TR from these factors, but we have developed our countermeasures while finessing our strategic intentions to adapt.

Focusing on recruiting functionally appropriate resources to support compliance and our continued expansion, while significantly investing in our global manufacturing footprint and supply chain partners to reduce supply chain risk and enhance our product offering. Blend this approach with resilience (noun, the capacity to recover from difficulties, toughness) and we find that hybrid working, remote communication and a lack of in-person contact are no barriers to outstanding teamwork.

But in a world of change, pressures, KPIs and measurements perhaps the words that need counting more than any other are those that express gratitude and appreciation. I trust I speak for all of you reading this article when I pause to sincerely pass two words to our colleagues, customers and suppliers – thank you (noun, an instance of expressing thanks).





New Legislation 'The Right to Repair' in 2022

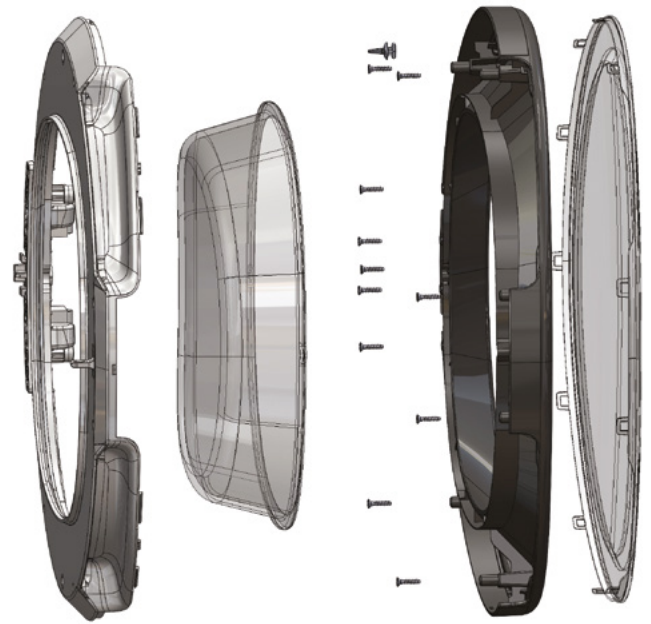

The environmental 'Right to Repair' legislation has put the consumer back in charge of their electrical goods and helps to address the 'throwaway tech culture' head-on which TR Fastenings supports. After years of campaigning this EU legislation will drive change in assembly methods with a major shift in how electronics and domestic appliances will be manufactured and serviced. It is already playing a key role in helping to extend product life, cut carbon emissions, and reduce landfill. Where there are more mechanical assembly methods employed there could even be a boost to create more jobs within the industry sector.

Benefit to consumers

Currently if an electrical product or domestic appliance develops a fault, having the ability to source spare parts and fix it yourself, or use an independent repairs service provider, has always made perfect sense. However, this has not really been possible for a long time. Today if you attempt to repair electronic goods or appliances it negates the warranty, so manufacturers have always sought to discourage it. The expected redesign of appliances will reduce products being welded for example which currently makes them inaccessible and therefore less likely to be repaired. As a major supplier to the Health and Home market TR is actively supporting new designs and the re-introduction of fasteners so that they can be accessible for disassembly and repair.

Benefits of repair over new

Repairing a broken component part instead, particularly where the rest of the appliance works fine, saves the end user money in the first instance. Therefore, the need to replace a machine is much less likely, and it extends the life of the repaired product which in turn cuts down carbon emissions. It also helps the environment at both ends of the supply chain, even potentially creating jobs in the independent repair sector.

Sven Brehler, Director of Engineering commented:

"This is a very positive development that has been years in the making. While this is primarily about giving control to the consumer there is also a very strong environmental case here as well. It will mean that fewer companies will weld products for example and instead introduce fasteners back into their designs that can be undone/unscrewed providing extra accessibility for repairing items rather than having to always replace the entire unit. The environmental benefits are considerable, and this change will have wide reaching and a long-lasting impact on the manufacturing sector."

Loss to the economy

This started to change in July 2021, when new laws came into force requiring manufacturers to make spare parts much more available to consumers. It was particularly important in the electronics market, where global brands had increasingly prevented user access.



New Legislation 'The Right to Repair' in 2022

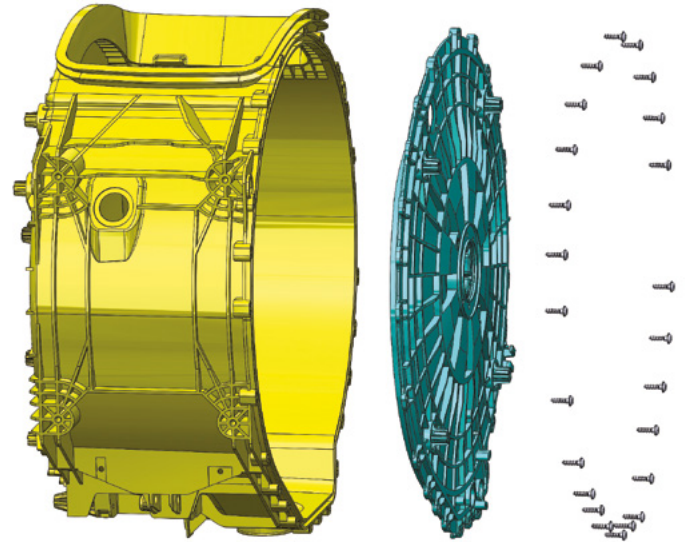

However, this was against a backdrop of growing concerns about electrical recycling and wastage.

It is estimated that 1.5m tonnes of electrical and electronic items get thrown away each year in the UK, at a cost of £370m per year,* which is an incredible figure in light of the sustainability net zero challenges.

For domestic appliances the change in legislation was long overdue and it will almost instantly start impacting the reusability of products and extending the lifespan of many domestic products, keeping items from landfill while reinvigorating the repairs sector. As we move further into what is widely anticipated to be an inflationary year this will help consumers extend product life and save money.

Impact on TR Fastenings

For TR Fastenings and its customers, the new legislation overhaul was a very welcome change, feeding directly into its Environmental, Social and Governance (ESG) strategy and drive to increase environmental responsibility wherever possible. TR is active across a number of different sectors including, Health and Home (H&H) and Energy, Technology & Infrastructure (E,T & I), all of which will be impacted by the changes. It recently announced a new significant investment in its TR VIC spa site in central Italy which serves some 24 countries around the world in the Health and Home and Light & Heavy vehicle sectors.

Karol Gregorczyk, Global Account Director for the Health and Home sector said:

"The new rules will significantly impact manufacturers. TR's customers collectively produce some 8-10 million washing machines and dryers every year, and they make spare parts available not only for washing machines and washer-dryers but also for dishwashers, refrigerators, and TV's for the first time. This move will open up new opportunities and the reduction in welding can actually prove cheaper for manufacturers while moving away from the creation of non-repairable white goods. TR is very willing to support companies and assist in redesign. TR VIC has a Technical and Design Centre within their manufacturing facility in Fossato di Vico, close to Fabriano which is near to many of the home appliance OEM's and their subcontractors."

**Source: <https://www.recycleyourelectricals.org.uk/problems-with-e-waste/>*





TR shines a spotlight on its new interactive 3D animations

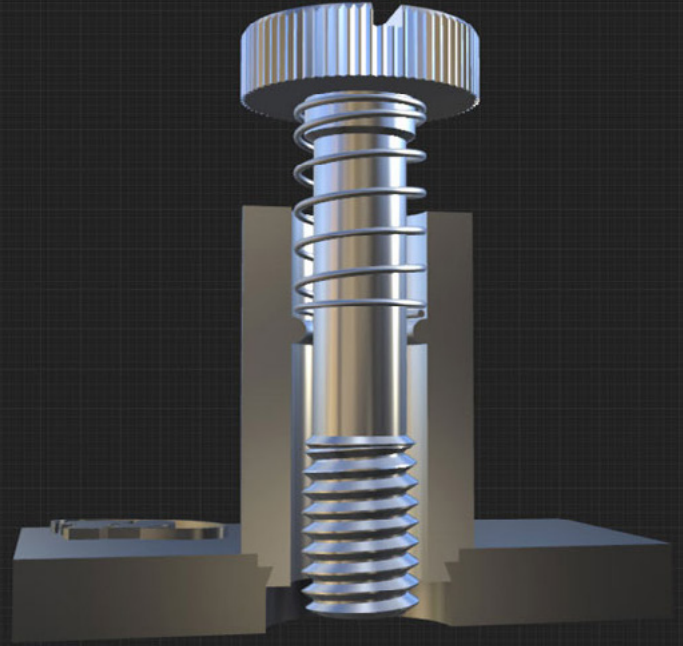

TR Fastenings Ltd (TR), part of the Trifast plc group, has launched new interactive 3D animations which help to make its products and installation methods easier to understand for buyers and design engineers, as well as being a beneficial training and educational tool. These real-time technical animations expertly demonstrate products, processes and concepts, which can often be complex and hard to visualise.

An immersive world

3D is all around us; it's in apps, movies and video games and as TR recognises that design concepts are changing, so must their visual portfolio.

There is growing worldwide demand for more interactive content, specifically within the fasteners industry which TR is fully embracing and taking advantage of with its animation know-how. It's fast evolving especially with Virtual (VR) and Augmented Reality (AR) starting to disrupt industrial design and engineering. With the advent of emerging technologies, manufacturing has become more complex, so the integration of VR and AR is enabling manufacturers to simplify these processes.

Accurate visualisation

Produced by TR's in-house visualisation team 3D models have been created following collaboration with their technical and design Teams. The key requirement of the animations is to

enable the user to accurately visualise products in different settings and formats. Time was spent refining the user interface, to produce models of TR's own brand products such as the [Self Clinch Fasteners](#).

3D product visualiser

Ever wondered what a Self Clinch Fastener looks like cut in half, or visualised the appearance of when it is fully assembled? TR believes this assists companies at the design stage and could be invaluable. A range of options enables the user to interact with the products in a variety of ways such as assemblies, cutaways, magnification, material types and installation. It's clever and clear.

There are currently around 50 products with the 3D product visualiser available on the TR website. The plan is for these to be an integral part of TR's ongoing content strategy as the industry forges ahead with offering visualisation technology to meet design engineering demands.

[Click here for an example of a Self Clinch Flush Head Stud 3D product visualiser.](#)

Installation animations

TR is able to show an entire installation process, end to end. What can often be difficult to explain is now much clearer and easier to understand using visual representation of the part in situ.





TR shines a spotlight on its new interactive 3D animations

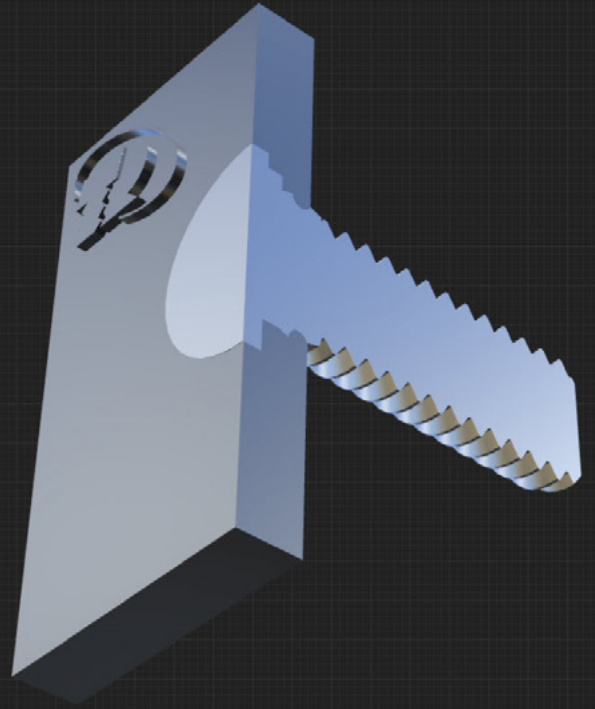

TR's installation animations are an ingenious way to demonstrate a virtual assembly and sub assembly in a simple way.

[Click here for an example of a Self Clinch Flush Head Stud 3D installation animation.](#)

Glenda Roberts, Global Projects and Marketing Director comments:

"We are delighted with our new series of 3D product visualisers and animations which are available for all of our customers. This represents a real step change in how designers and engineers can work with us. Virtual Reality and Augmented Reality technology has advanced significantly in recent years, but our industry has not fully captured that potential. We will continue to develop our offering to ensure we bring innovative concepts to life."

In May 2022, TR launched its new website www.trfastenings.com, which consolidated its previous investor site and corporate site into one digital front door for the group. It now includes a host of new features and enriched content, including a personalised user area, which helps to create a new experience for TR's customers and partners. In particular the [electric vehicle charging units](#) and [set top box](#) animations are leading edge.

To view individual product installation animations, visit [TR's product page here](#) and click on the product video icon or visit our [YouTube channel](#).

Article published August 2022





Modular design and standardisation

Credit: Torque Direct



Sven Brehler, Director of Engineering at TR Fastenings, discusses how intelligent fastener design could help to future-proof the electric vehicle sector.

As innovation within the electric vehicle (EV) market continues to gather pace, many manufacturers are looking at how modularity can improve the design, performance and overall lifecycle of current and future vehicles. Naturally, this move towards more modular designs is placing new demands on fastener manufacturers to develop products capable of meeting the requirements of more integrated components.

With 34 [locations](#) in 18 countries, TR Fastenings is involved at the forefront of fastener design and supply to the global automotive sector, in particular with the Tier 1's. The rise of the EV market has presented new opportunities – and challenges – for the fastener provider. The companies engineering, research and development capabilities enable it to work closely with its customers to develop products that are not only optimised in terms of design and performance, but also in regard to their recyclability, assembly efficiency, and overall lifecycle.

Sven Brehler, Director of Engineering at TR Fastenings comments: *“Now EV manufacturers are looking at modular design as a completely new concept. This is a great opportunity for us, as the initial design and concept of the application is*

where we can ensure fasteners become an integral part of the whole design early on. This specifically works well when looking at light-weighting, for example.”

Working with its customers from the beginning of the design process allows TR to not only optimise the design of the fasteners required for a specific part, but it also improves the overall sustainability of the vehicle.

“For example, let’s assume that a vehicle has an average lifespan of 12 years, after which it will need to be taken apart so that its components can be recycled and reused,” Brehler explains. “Anything that we do not get right up front, we will pay for later on. It’s becoming much more important to also look at the reusability and recyclability of the products used in EVs at the early design stage.”

Whereas in the past automotive manufacturers have leaned towards gluing or welding parts together to create permanent fixings, the increasing importance placed on improving the lifecycle of new vehicles means it is important that these units can eventually be taken apart. We are already seeing assembly methods changing in other industry sectors with the new legislation in Europe, [‘The Right to Repair’](#).

“The move towards modular design is where it gets interesting” Brehler adds.





Modular design and standardisation

Credit: Torque Direct

Continued



“With every new development, it opens the door for us to look at reapplying or developing new products and bespoke items that will ultimately improve the recyclability and sustainability of future vehicles. Embracing modular design can help to elongate the life of not only the parts themselves, but also of the entire vehicle as it allows various components to be replaced, which has often not been possible previously.”

Although known widely for supplying threaded fasteners, TR Fastenings also supplies bespoke product such as [Compression Limiters](#) and [plastic components](#), increasingly used in assemblies e.g. battery housings. Such items are designed in line with new technical challenges posed by the rapid acceleration of EVs and battery technology, requiring capabilities such as heat and [cable management](#), conductivity and electrostatic finishes.

“With light-weighting, we are seeing more aluminium and high tensile steels being used, which pushes the boundaries of current products,” Brehler explains. *“We are also seeing requirements for silver-plated and tin-plated parts for connectivity, as well as special plastic parts that work as a barrier or in closing the battery packs or cable management. The EV market is providing many more opportunities to develop new products with our customers.”*

Of course, the rapid advancement of EV technology is not without its challenges, Brehler

admits. In particular, the sector is currently lacking standardisation. He gives EV charging plugs and units as an example, the compatibility of which often varies between the vehicles of different manufacturers. With no globally agreed standard, people have little choice but to replace their charging units when they purchase a new vehicle, which is both costly and creates unnecessary waste.

This is also seen on the battery side, Brehler observes. As there is no standardisation for the chemistries used within batteries, they must be separated individually in order to be disposed of or recycled.

“It is not only the development of new products, but also the application of new products which is becoming very important,” he says. *“Being able to integrate an existing fastener that has already been tested and proven into a customer’s application is just as important as developing your own product. So, if you can find a new application for a fastener that has already been tried and tested, you have already covered that part of the process.”*

This is something that TR Fastenings is keenly focused on: *“This is actually driving the technology forward and helping to further develop the existing products we have.”*

An example of this is the company’s [EPW Self-Extruding Screw](#), which Brehler says was developed initially for the white goods sector.





Modular design and standardisation

Credit: Torque Direct

Continued



The TR team have developed this even further as this product has potential to be used for the EV market.

“We have seen a lot of innovation, ideas and technology from the electronics and telecoms industries moving into the existing automotive market, and that is why we are seeing so many changes in design and development,” he says. “We are able to take our experience and expertise from other industries and apply it to the EV sector.”

This transfer of knowledge and innovation has also been seen in the Formula One market: *“Formula One is moving towards the electric vehicle and they are pushing the industry forwards massively,”* Brehler observes. *“We can see them adopt some of the technologies we are looking at, especially light-weighting, through looking at different types of screws that push the boundaries and drive weight down. Taking things apart is also extremely important in Formula One, so we can see those benefits already carrying through from different industries into the mainstream EV market.”*

Returning to the need for improved modularity and standardisation in the EV market, Brehler believes the two concepts go hand-in-hand.

“The lifespan of EVs is going to increase due to less moving parts and other factors such as autonomous driving leading to less wear and tear, which means there will be a greater focus on the coatings on fasteners within these vehicles,”

he explains. *“Corrosion will be one of the major feats we have to overcome, because you can’t take a corroded fastener out of a vehicle, which will impact the recyclability process. How will we take apart a vehicle in 30 years’ time? That’s what everyone is talking about now, and that is what will prompt global standardisation within the industry going forwards.”*





TR Fastenings opens new facility in Hungary



TR Fastenings Hungary Kft, part of the Trifast plc Group, is celebrating the opening of its new purpose-built facility in Budapest, building on years of rising demand in the region.

Located in the southern suburb of Szigetszentmiklós, Budapest, TR Fastenings Hungary Kft is a fastener and Cat C supplier to international OEM's and their subcontractors not just in Hungary but in the seven countries that border them. The new 3,500 sq. metre modern facility has 9.5 metre eaves in the warehouse and is a high-capacity distribution facility that is ready to support TR's future European growth strategy.

TR Hungary was first established in 2000 and has grown considerably in that time, quickly outgrowing two previous locations. Its rapid growth has been a real success story for TR and the region alike. It has come about through rising demand from large multinational household brands, many of which TR supplies to elsewhere in the world. Hungary has historically been a lower cost production region but with a highly skilled available workforce making it ideal for this kind of strategic investment. Hungary has a central location in Europe with seven countries on its border, which is perfect for distribution hubs.

A region growing in opportunity

Glenda Roberts, Global Projects and Marketing Director, Trifast plc, said: "*Hungary has been a real success story for TR. Local infrastructure has*

been enhanced with the second airport and the recently enhanced road network. We located to a fast growing industrial park off the M0 motorway, which proved to be a very fortuitous move as one of our largest customers NCR moved in just 600 metres away from us. Over time we have built a portfolio of multinational customers that expect the same excellent service that they receive from TR globally. This includes technical and engineering support, as well as logistics services."

She went on to say: "*We're servicing these major customers in each of the countries surrounding the TR Hungary operation and inevitably we have had to expand again. It took several years because of the growth in Hungary to locate a new facility close to the existing site to grow into but we are very confident of the investment. We were very keen to retain trained staff, many of whom are also multilingual, so we ensured we did not move too far away. Product knowledge and an understanding of the level of service our multinational customers expect was a key staff retention factor, but we wanted to go further. The new facility is a showpiece modern workplace, where people have a great working environment and where customer and staff training sessions and customer site visits can also be held."*

Andrew Nuttall, European Managing Director at TR Fastenings, managed the project team and the move to the new facility.





TR Fastenings opens new facility in Hungary

Continued



He said: *"I'm very proud of what the TR Hungary team, under the management of Zoltan Csengeri, have achieved. Moving an entire facility in a month to a new location was no mean feat and now that we are established, we look forward to focussing on customer and staff development and growing our business in Central Europe".*

"We were really working with a blank canvas and it enabled us to incorporate the environmental and sustainability features and benefits for a truly modern workplace. The facility is in a green area, with fields to the exterior, on a purpose-built estate with excellent transport links. Every feature was thoroughly researched from the solar panels on the roof to the triple glazing. It includes full air conditioning, with added air quality monitoring equipment to ensure the comfort and wellbeing of our workforce. Automatic shutters on the warehouse roof windows assist in cost effective temperature control, while electric charging units have been installed to encourage the use of electric and hybrid vehicles, including company vehicles.

He concluded by saying: *"We even engaged the service of a company to ensure that the ergonomics of the office furniture and other fittings came from a proven sustainable source and we have focussed on the ambience, the colour palette and comfort, which included break out seating areas to enhance the working experience. Due to the large footprint of the building, it is*

mandated by the Hungarian authorities that we had to create a water catchment pond beside the warehouse for rainwater drainage. This is regularly checked and assessed for pollution levels, and our intention is that it becomes a feature with reed beds and planting to encourage wildlife and enhance the aesthetics of the building,".

The TR Hungary team is fully supported by the Group encompassing Sourcing, Technical and Design, Commercial, Financial, HR and Marketing support.





Women in Engineering: breaking the myths

Credit: Eureka, Mark Allen Group



TR Fastenings' Global Projects and Marketing Director, Glenda Roberts, discusses the importance in breaking down the myths of women in engineering.

According to a report by [EngineeringUK](#), women make up just 16.5% of all engineers - women remain underrepresented in the engineering sector. Glenda's experience in a variety of differing roles within TR Fastenings, a leading specialist in the design, engineering, manufacture and distribution of industrial fastenings, means she has developed extensive knowledge on how products are produced and manufactured from start to finish. Glenda has seen a difference in gender ratios both within TR and at their customer base over the last 30 years.

Glenda Roberts, Global Projects and Marketing Director comments: *"A career in Engineering was perceived as 'you'll get your hands dirty as you'll be in an oily production environment.' In truth, it is a million miles away from that because much of the product we produce is often electronically or robotically assembled in very clean facilities.*

Crack the Code reported that education systems are vital in determining girls' interest in STEM-related subjects. The engineering stereotypes, such as it being a 'male industry' and 'dirty' is "a myth that needs to be exploded."

Numerous organisations and higher education institutions are working to close the gender gap in engineering. For instance, the Government's T-Level courses include STEM subjects such as Engineering and Manufacturing. Glenda stated, *"we need to educate people more generally about the opportunities within an engineering environment, specifically women. It is about understanding what engineering means - being*

able to see a product from inception all the way through to the final part." TR's new website, created in house, features an extensive [Knowledge Base](#) of engineering data, and interactive product and sector animations. TR is increasingly seeing their data being accessed by universities as STEM becomes the hot topic in education.

Despite a rising figure in the proportion of women entering undergraduate courses in STEM subjects, there remains to be an unmet demand for higher-level STEM skills in manufacturing, construction, engineering, science, and technology ([Gov.uk](#)). "It is about opening people's minds up to how extensive the engineering opportunities are."

Breaking the engineering stereotypes will open doors to many people, including women, to a very diverse career path. 85% of the product that TR manufactures and distributes is customer specific, which not only means a variety of parts, but also gives young women the opportunity to experience varying applications - across all sectors.

"I can't think of many careers that you can have an involvement in such a diverse range of products and very varied companies across sectors to engage with."

"I have never found working in engineering a barrier because I am a woman." With 32 years of experience in the industry, Glenda has travelled internationally in her job, and the changes she has seen include an increase in women working within the production environment across a range of skill sets. Glenda's attitude towards STEM and determination in showcasing what engineering truly is, is an inspiration to young women having doubts about kickstarting their career in engineering.





Staff at TR's West Midlands location show their continued support and donate to multiple charities

**BLACK COUNTRY
FOODBANK**
LOVE . CONNECT . INVEST



Staff at TR's West Midlands location continue to show support to those in need. Each year they donate to a local charity instead of sending Christmas cards to each other.

For 2021, the team decided to split the donations between two charities they have previously supported, the Black Country Foodbank and The Salvation Army.

The team raised an impressive total of £430.00, £210.00 was donated to The Salvation Army and £220.00 to the local Black Country Foodbank, who issue food vouchers to local organisations that encounter people in hardship.

Jackie Taylor, Operations Manager at TR's West Midlands location comments:

"Thank you to Jayne for making the fundraising event a huge success. Thank you to everyone who donated. Everyone should be really proud of themselves for making a difference in the local community."

Lieut-Colonel Dean Pallant, The Salvation Army comments: *"I'm writing to say a truly sincere and very warm 'Thank you' to you. You are a shining star! Our Christmas fundraising is so important and when we start our appeal, I always offer a prayer and express a hope that it will deliver the funds we need to continue our work. That's why I'm so grateful that you made a donation. The Salvation Army is busy all year round, but the winter and*

Christmas season is a time when we really do step up our caring work.

We're here for families who have so little, to help make sure they feel supported and that children have a small present to open on Christmas Day. We're here for older people; without us, many would have little or no company at this time of year. We're here for people who are homeless or battling addictions or recovering from forms of slavery-these people need us more than ever at Christmas time.

Christmas is a time when we think of others. Your donation will help us do more than think, it will help us deliver care, the kindness and the practical support that is at the very heart of The Salvation Army."





TR Fastenings' North East team take on the Macmillan Mighty Hike!



The hike will take place on 16th July at Alnwick Castle, where they will walk 26 miles, from Alnwick Castle to Bamburgh Castle. The hike will be along the beautiful beaches and fishing villages of the Northumberland coast.

Macmillan Cancer Support, one of Britain's largest charities, founded in 1911, offers dedicated care and support to anyone who is affected by cancer. In 2018, the charity was able to reach 6.7 million people who were affected. By people raising money for the charity we are able to ensure their great work can continue.

Katie and Donna comment: "Having lost both family and colleagues to cancer Macmillan is a charity that's very close to our hearts, were not the most athletic so no doubt will ache from head to toe but it's all for a very worthy cause."

If you wish to donate and support the team please visit Katie's JustGiving page [here](#).



TR Fastenings to sponsor the Uckfield Business Awards 'Best Workplace Award' category

Proud to sponsor the
'Best Place to work' category

UCKFIELD
BUSINESS
AWARDS 2022

TR Fastenings is proud to sponsor the 'Best Workplace Award' category for the Uckfield Business Awards. Launched in 2012 the awards are held annually and are open to businesses across Uckfield and surrounding areas.

This year the awards (backed by the Uckfield Chamber of Commerce) will be held at the East Sussex National hotel on Thursday 29th September 2022. Nominations will close on the 13th June and entries will close on 17th June.

The 'Best Workplace Award' will be awarded to a business that delivers an outstanding business environment in addition to an ethos that promotes and supports employees, meaning the business will provide dedicated resources and time to ensure staff wellbeing is priority, this is something that is really valued in our organisation at TR Fastenings!

Warren Dipper, Group HR Manager at TR Fastenings comments:

"To win the 'Best Workplace Award', a business needs to show real commitment, and tangible evidence of why they believe they are the best place to work. I am excited that TR are not only sponsoring this award, but additionally, we will choose the shortlist and winner!"



TR's Midlands Team walk the Race for Life in honour of a colleague and friend



On Sunday 3rd July, 13 TR employees and 3 friends will take part in the Race for Life, Himley Hall, Himley Park, Dudley.

Starting at 11 am they will begin their 5K walk, passing the lake and Himley Hall, making this a very picturesque course.

The Race for Life is Cancer Research UK's biggest series of fundraising events, beginning 28 years ago.

Jayne Rogers, from TR's Birmingham site

comments: *"We are walking in memory of our colleague of 15 years, and friend Carol Wiffen who sadly passed away in March this year from Cancer aged 57.*

We are walking in the name of Carols Clan and have set a goal of £1,000 for this worthwhile charity and so far, have raised sponsorships of £640.00."

All donations go towards Cancer Research UK's lifesaving work, here is how your donation can make a difference:

- £5 kits out one ground-breaking research labs
- £12 buys a lab timer to keep scientists on track as they go about their work
- £20 covers the cost of running Cancer Chat for one hour and can also buy a new bulb for microscopes, illuminating minute details of cancer cells.

- £30 is the cost of running a cervical cancer trial for one day

To read more about the Race for Life, Himley Hall, simply [click here](#).



The TR Midlands team smash their £1,000 target whilst joining hundreds of runners at Himley Hall



On Sunday 3rd July, TR employees and their friends took part in the Race for Life, Himley Park, Dudley. The team, who were joined by 900 other participants, had a very successful walk, and raised an impressive £1,650.00 through generous donations from fellow staff members, friends, and family.

A grand total of £33,000 was raised by all attendees who took part in the race at Himley Hall, this is an amazing total and will make a great difference to Cancer Research and the people sadly affected.

The TR WSP team commented:

"We lost our friend and colleague Carol in March to cancer, in addition to a rose bush and bench at TR WSP and just because she was such a big part of our TR family here, we wanted to do something further in her memory that we could all be involved in, so Leanne suggested race for life and we all agreed so we could raise money for cancer research and at the same time pay tribute to Carol.

At the end of the race we also pinned our race for life memory card with a picture of Carol onto the memory wall."

Andy Johnson - Operations Director TR Fastenings Birmingham comments:

"I am so proud of the Waterside Park Team for remembering Carol in this way, and the wholehearted contribution that has been given to

this very worthwhile Charity"

The team were also featured in the Local Express & Star! [Click here](#) to view.



TR Uckfield finds fundraising a piece of cake for Macmillan Coffee Morning



Employees at TR Fastening's headquarters in Uckfield, raised an impressive total of £1,000 for [Macmillan Cancer Support](#) on the 5th October. Cakes flew off plates raising the impressive total thanks to the all the skilled bakers and donators!

Macmillan reports that this year the Coffee Mornings raised an incredible total of £5,394,537, this can fund 86 Macmillan nurses for a year!

TR's Katie Treacy, Operations Manager at the headquarters in Uckfield, Comments:

"A massive thank you to all the staff who baked and donated to such a great charity that supports so many people. We are really pleased to have been able to donate over £1,000, yet another amazing year of cake selling! We believe fundraising is a great way to help increase awareness and we all look forward to next year's event"

Click [here](#) to donate to Macmillan.





Trifast's Christopher Morgan completes the London Marathon raising over £11,000 for The Back Up Trust



Trifast's Company Secretary, Christopher Morgan joined more than 42,000 people who participated in the 26.2 mile course, in this year's London Marathon on the 2nd October, using his wheelchair. The London Marathon is the 2nd largest annual road race in the UK, and is one of the global marathon majors.

Christopher completed the marathon in an impressive 4 hours 31 minutes, whilst taking in some of the most famous landmarks in the city - including Buckingham Palace, The Cutty Sark, Tower Bridge (as pictured below) and Canary Wharf.

Christopher, Trifast's Company Secretary comments:

"As you probably know I love a challenge, and when the opportunity came along to participate in the 2022 London Marathon, there was no way I was missing that.

What an amazing day, full of positive energy and motivational crowds! Thank you to my incredible training and running partner, Matt Hunter, in getting me to this point. It has been an incredible journey.

I did the London Marathon to raise money for [The Back Up Trust](#), whose vision is to ensure anyone with a spinal cord injury (SCI) can realise their full potential and have supported everyone with SCI for over 30 years."

Christopher, who is also a Board Trustee at Back Up and his friend Matt raised an incredible amount for the charity, over £11,000, and combined with the other Back Up runners/wheelchair participants, the charity secured over £36,000!

The donations support Back Up in delivering:

£15.00: Pay for a series of vital outreach telephone support calls to someone leaving hospital and adjusting to a new life.

£35.00: Pay for wheelchair skills for someone who is newly injured to help them learn essential skills to tackle ramps and kerbs and get around independently.

£50.00: Provide support to children as they settle back into school life, ensuring they are fully included in all aspects of education.

Abigail Lock, Back Up's CEO commented :

"A genuine thank you to everyone who donated. This means a huge amount to Back Up and will allow the charity to continue delivering on rehab programmes, wheelchair skills training, skiing, and outward-bound courses."





Local town church 'spruce's up in time for a 'Tree'mendous Christmas display

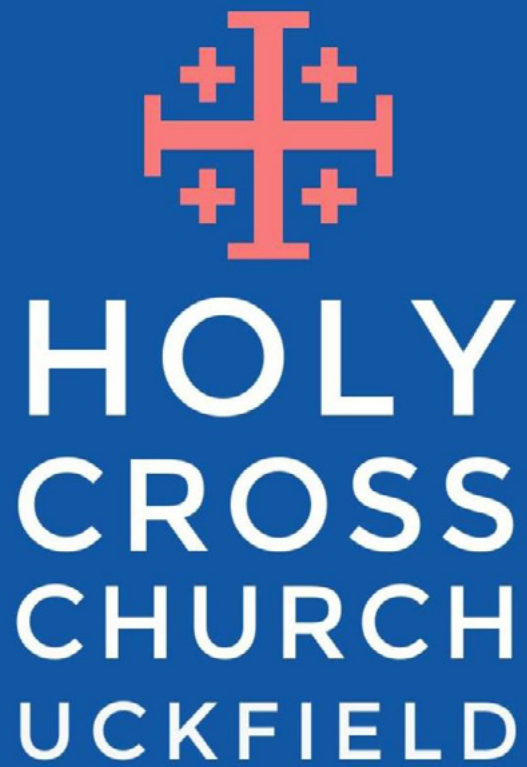

TR Fastenings headquarters in Uckfield have donated £150.00 to support the annual local [Holy Cross Church](#) Festival of Christmas Trees. TR's donation will enable the church to purchase the recyclable cups for the festival.

The festival opens the first weekend in December (Friday 2nd- Sunday 4th) and is free to attend, each year attracting over 5,000 visitors!

Holy Cross will showcase more than 100 decorated trees from local organisations and will be full of festivities and fun for all the family, including gift stalls and children's crafts!

Visitors will be able to indulge in all things Christmas, with mulled wine, refreshments, and hot lunches!

Sarah Widdowson, Organiser, Festival of Christmas Trees 2022 comments:

"We have so many wonderful plans to make this year's Festival something very special for the whole community, so please pop the dates in your diary! The 100 + trees that are displayed in the church throughout the weekend are all sponsored and supported by local organisations, schools, charities, youth groups and businesses.

We are always so humbled that visitors come from far and wide to enjoy this event and the sense of community is clearly visible, from the moment you enter the church.

It's wonderful to have another highly regarded local business involved in this wonderful event! We look forward to welcoming you to another spectacular Festival!"



TR Scotland concludes 2022 community support with local Christmas food bank donation



The TR team in Scotland conclude 2022 with a community donation to a local food bank. The team will be donating £100 worth of food to EK Community Food Bank, across the next three months, during a period where families enduring hardship may struggle the most.

Having completed many successful food drives prior, the team know how much this means to so many families, allowing them to have a better quality of life especially in the winter months is so important.

The East Mains Baptist Church, part of the East Kilbride churches, works together for the food bank. They are able to provide a short-term care initiative to those families facing difficulties and who may not have enough to buy the necessities they need.

Stuart Harkness, Operations Manager at TR Scotland comments:

“It’s a sad fact that in our local area, many families and individuals are unable to provide for themselves and their loved ones, therefore they rely on the local food banks to ensure they have enough to eat.

Christmas is especially challenging for many families, the drop-in sessions are held every Monday from 10:30 am – 12:30 pm, where people can enjoy a hot drink and a roll.”

The East Mains Baptist Church comment:

“Our volunteers would love to sit and chat with you. We give information about Christians Against Poverty, Alpha and anonymous groups such as: AA, GA and CA. Each person is given a bag of food weekly and toiletries once a month if required. “





TR Fastenings in Houston is proud to have once again been awarded 'Distinguished Supplier' status by Yanfeng North America



YFAI Leadership Team commented,
"Congratulations on achieving a Yanfeng Supplier Award."

Each year, Yanfeng pauses to recognise our supply base and their significant accomplishments over the prior year. Yanfeng understands and appreciates that our supply partners are an integral part of our success. As we reflect on 2021, we realise that there have been unprecedented challenges for both YF and our supply partners. However, in spite of these challenges, you have stepped up to the challenge and performed at a very high level. Thank you for that extra effort to execute in this challenging environment and your continued efforts to perform accordingly in the future.

On behalf of Yanfeng's Global Leadership and the NA Procurement Leadership Team we extend a recognition award to you for your performance in 2021. Yanfeng greatly values you as a current and future supply partner. Congratulations and thank you!"

Scott McDaniel, MD of TR Fastenings NA, comments:

"The TR Houston Team and I are delighted to receive this award. Brad Allen and Jose Vera, with the Internal Support Team, are very dedicated in their support of Yanfeng and it is great to see that this has been acknowledged, as we value this relationship."





Trifast scoops IR Society's 2022 Best Annual Report Award



London: Wednesday 23 November 2022

Trifast (TR) was delighted to add another award to its awards library.

Last night, the Group received recognition at this year's IR Society's Best Practice Awards 2022, the showcase event that recognises excellence in all aspects of City and financial communications for companies across a broad range of sectors, from the FTSE100 to Small cap.

Shaping a reputation and building confidence with investors, the [Annual Report](#) is the main benchmark that provides an invaluable opportunity for companies' to engage and profile its business and investment opportunity with the City investment community wealth managers, independent investors, and other associated stakeholders.

Against strong competition Trifast picked up the 2022 [Best Annual Report](#) accolade in the Small cap category. The awards ceremony was held at the Landmark Hotel, London and attended by over 450 guests from 192 companies on Tuesday evening (22 November).

The judging Committee, headed by Paul Lee was looking for companies to demonstrate that the annual publication provided a sense of purpose, culture and identity supported by evidence of clear and concise communications, consideration of key stakeholders' needs and how these are met

through both in the hard and in the digital format.

Receiving the top award, Abi Burnett, Head of Marketing at TR said:

"I am delighted to have collected this award on behalf of everyone at TR. We strongly believe that our annual report is a 'shop window' in to the Trifast business, particularly reflecting our strong culture and collaboration with our customers and global workforce. It also delivers a holistic story that clearly demonstrates the effectiveness of both the business model and strategy, governance and broader social purpose."

"I would also like to recognise our external partner Lyons Bennett for their contribution to the 2022 project and we are looking forward to working with them on next years publication too."

Trifast CEO, Mark Belton added:

"Firstly congratulations must go to the Trifast team who have been recognised once again for their work. Our corporate reporting is a continuous improvement project where every year we aim to deliver the investment proposition in an informed, innovative and interesting format both in print and online as part of our digital marketing initiatives. We are delighted to be acknowledged by external professionals for the work and investment we put into the annual publication and all of our communications with the investment community."





TR Fastenings' Andrew Fletcher to speak on plastic fasteners at Engineering Solutions Live 2022



TR Fastenings is delighted to be supporting this year's Engineering Solutions Live Show, on 24th March 2022 at the British Motor Museum in Gaydon, Warwickshire.

The show is the UK's one-stop shop for thought leadership and meeting new contacts in the engineering sector. It provides visitors with the opportunity to visit market-leading solutions providers, networking with senior decision-makers from across the UK whilst boosting knowledge during expert-led seminars.

Andrew Fletcher, Director of Plastics & Rubber (Commercial & Technical) at TR Fastenings, will be presenting an 'Introduction to Plastic Fasteners' in a Fastening and Joining session. He will cover the key opportunities and challenges that exist around plastic fasteners and will provide an insight into best practices around specifying the most suitable product for an application. The seminar will also cover the important aspects to consider to help prevent product failures and costly design changes and give guidance on the common mistakes to avoid.

Andrew will examine some basic properties of plastic fastener materials and will cover the features and benefits of typical fastener types. He will round off the session with a look at how TR can offer collaborative support to customers to ensure that the right part is specified first time.

The five key takeaways from the seminar will be:

1. Importance of early design collaboration
2. Steps to establishing the best type of fastener for an application
3. Understanding of basic properties of popular fastener materials
4. Features and benefits of plastic fastener types
5. Common mistakes to avoid when choosing a plastic fastener

TR will also be exhibiting during the show and will be on Stand 32. If you are not able to attend the seminar, do please visit us and meet the team on the day.

More about Andrew

Andrew Fletcher is the Director of Plastics & Rubber (Commercial & Technical) at Trifast plc. Before joining in February 2021, he was Managing Director and Technical Director at Optimas Solutions, previously known as Heyco then Anixter. He spearheaded New Product Introductions, managing the entire process from initial inception through to final product launch. With more than 27 years in his field, Andrew is highly regarded due to his deep knowledge of the industry.





Getting the message across at the Engineering Solutions Live Show 2022



TR Fastenings has played a pivotal role at a wide variety of trade shows and exhibitions in recent years, and we were particularly pleased to have been represented at the recent Engineering Solutions Live Show. The March 2022 event was held at the iconic British Motor Museum in Gaydon, Warwickshire, and was attended by a significant number of thought leaders and decision-makers from a comprehensive range of organisations.

Andrew Fletcher, our Director of Plastics & Rubber (Commercial & Technical), hosted an important presentation on an 'Introduction to Plastic Fasteners', attended by a cross-section of manufacturers, materials suppliers and training providers. It served as a practical and enjoyable way to get the message across about the feasibility of plastic fasteners and the best practices in their usage. Also featured was information on preventing lengthy product failures and avoiding expensive design changes.

Events such as this enable TR Fastenings to underline the importance of early design collaboration across all of the industry sectors that we serve. Plastic fasteners are versatile, affordable and easy to adapt to specific usages. And as well as informing influential individuals from across the engineering spectrum, Andrew was also able to field questions from attendees, thereby helping to cement a greater understanding of our products.



TR Fastenings joins high calibre of 2022 Expo sponsors

You're invited!



29th September 2022
Beacon of Light, Sunderland

Stand
B36



Established in 1973, TR Fastenings is the trading business of Trifast plc, and is a global specialist in the design, engineering, manufacture and distribution of a comprehensive range of high-quality industrial fastenings and assembly products primarily for the Automotive, Electronic and Technology, Domestic Appliance, Distributors and Industrial Sectors. Own brand products include rivet bushes, self-clinch fasteners, screws for plastic, blind rivet nuts, self-locking nuts, security fasteners, plastic fasteners, cable management products and our new range of enclosure hardware.

TR Fastenings has been a member and supporter of the NEAA since its inception and has sponsored the North East Automotive Expo for a number of years. In 2022 the company has come onboard as a Partner Sponsor.

Chris Black, Director of Automotive New Business Development at TR Fastenings said: *"We are very pleased once again to be able to support and participate in an NEAA event. Their proactivity in bringing people together, with interesting topics and agendas is always an event that we benefit from. We are looking forward to attending."*

Paul Butler CEO at the NEAA said: *"We have worked closely with TR Fastenings since 2015 when the NEAA was first set up. As an active member they support initiatives and maximise the benefits of working together as a regional cluster. I'm delighted TR Fastenings are once again a key*

sponsor at the Expo, and we hope this year's event is as fruitful for them as it has been in previous years."

TR has recently launched new interactive 3D animations which help to make its products and installation methods easier to understand for buyers and design engineers, as well as being a beneficial training and educational tool. These real-time technical animations expertly demonstrate products, processes and concepts, which can often be complex and hard to visualise.

Produced by TR's in-house visualisation team 3D models have been created following collaboration with their technical and design Teams.

TR is able to show an entire installation process, end to end. What can often be difficult to explain is now much clearer and easier to understand using visual representation of the part in situ. TR's installation animations are an ingenious way to demonstrate a virtual assembly and sub assembly in a simple way.

In May 2022, TR launched its new website www.trfastenings.com, which consolidated its previous investor site and corporate site into one digital front door for the group. It now includes a host of new features and enriched content, including a personalised user area, which helps to create a new experience for TR's customers and partners. In particular the electric vehicle charging units and set top box animations are leading edge.





TR Fastenings to exhibit at OTD Energy Bergen

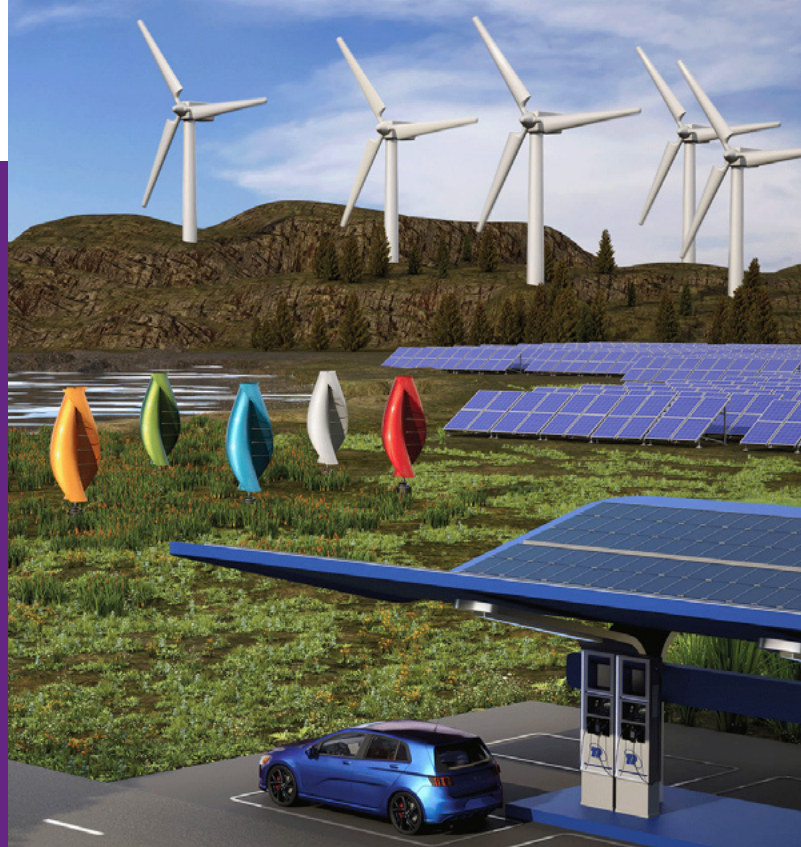

19th to 20th October 2022, Norway, Stand B - 2070

TR Fastenings is pleased to be supporting [OTD Energy 2022](#) this October. The event, held in Bergen, Norway has developed into the leading meeting place for companies working in the oil, energy and offshore industries, and TR's involvement will raise its profile in the field of sustainable innovation.

Offshore Technology Days (OTD) has been running in Norway since 1999, and has become increasingly influential in building connections amongst individuals and partnerships between companies within the industry. It presents future focussed business opportunities for suppliers and manufacturers working in the solar, hydro, EV and wind sectors amongst others.

As around 80% of the world's industrial energy comes from fossil energy sources, there is a global drive to replace these with renewable, sustainable and green energy alternatives with carbon neutrality by 2050. OTD Energy has become a key event in bringing together the traditional and future energy industry into one place, where sustainable market opportunities can be explored.

OTD is the ideal event for TR to showcase its capabilities in this sector. With a clear vision for sustainability, TR has a focused strategy that will help to shape a sustainable economy using its in-house expertise to drive innovation that adds value

to society and the planet.

Within the [Health and Home](#) industry, the 2022 'Right to Repair' EU environmental legislation was welcomed by TR. Feeding directly into TR's Environmental, Social and Governance (ESG) strategy, we will now see a change in how electronics and domestic appliances are manufactured and serviced which will result in a longer product life, a cut in carbon emissions and reduced landfills. TR actively supports new designs and the re-introduction of fasteners, with early involvement at design stage.

Visit the TR team on stand B - 2070:

Jan-Erik Storsve
General Manager
TR Fastenings Norge AS
Email: jan-eriks@trfastenings.com





TR Fastenings to exhibit at the Advanced Engineering Show

You're invited!



ADVANCED ENGINEERING



2 & 3 November 2022
NEC, Birmingham

Stand
G151



2nd & 3rd November 2022, NEC, Birmingham, Automotive Engineering Zone, Stand G151

TR Fastenings is delighted to be exhibiting at the Advanced Engineering Show 2022 in November at Birmingham's NEC. At this high-profile industry event, TR will be displaying products and applications through interactive showcases, within an eye-catching and spacious stand allowing comfortable visitor engagements. Positioned in the Automotive Engineering zone, TR's stand is in a prominent position close to the Open Forum, the Aerospace/Automotive Networking Area and the VIP Lounge.

The Advanced Engineering Show, now in its 13th year, represents a great opportunity to network with innovators, designers and specifiers within differing manufacturing sectors. The Automotive Engineering zone is a dedicated area within the exhibition for vehicle manufacturing and supply chain engineering. The NEC is the largest event space in the UK, and it will be home to seven show zones and four forums with more than 400 exhibitors.

Visitor engagement will be crucial during the event. TR will be showcasing their latest 3D product visualizers, product animations and the TR Smart City on multiple screens which are designed to show where product is used and how it is assembled. These are new tools to assist that are focused on product design, and gives a

better understanding of the scope of supply that TR can both manufacture and deliver. These will help new and existing customers to understand the benefits of working with TR from design through to installation and beyond. The Advanced Engineering Show dovetails perfectly with TR's culture of innovation and technical support.

The engineering and manufacturing sectors are constantly evolving, and TR has been quick to adapt to the complex needs of industry. TR's fastening solutions have a strong focus on Value Engineering by way of early engagement to provide proactive support to customers.

Areas of interest at the show include electric vehicles, engine manufacture, components, supply chain, procurement, systems engineering, technology transfer, consumables and more.

Visitors to the Automotive Engineering Zone will include those working on both high and low volume vehicles for personal, commercial, industrial and military usage. For all exhibitors, including TR Fastenings, the chance to engage with the manufacturing and engineering communities is not to be missed.

Sven Brehler, TR's Director of Engineering is amongst the speakers at the event.

"Sustainable fasteners are a key area for discussion with the drive to reach the heady targets of net zero.





TR Fastenings to exhibit at the Advanced Engineering Show

Continued



Additionally, with the increasing needs in the EV sector and battery production both materials and finishes are key areas of development to fulfil new requirements, and we are rising to the challenge.

New legislation in Europe is mandating the 'right to repair' in certain industries after the warranty period has expired. Please visit us on the stand and we can discuss in more detail."

TR is committed to the concept of a circular economy, with stronger emphasis on using recyclable materials and improved supply chain practices. TR works closely with customers to define and adopt more sustainable processes and will continue to raise awareness through events like the Advanced Engineering Show.