



Self Clinch

Product Brochure



part of the Trifast plc Group





Studs

Flush Head Stud - TR-FH/TR-FHS/TR-FHA/TR-FH4	3	Low Displacement Stud - TR-FHL/TR-FHLS	7
Concealed Head Stud - 1.6mm Sheet - TR-CHC/TR-CHA	4	Broaching Stud - TR-KFH	8
Concealed Head Stud - 2.4mm Sheet - TR-CFHC/TR-CFHA	5	Thin Sheet Stud - TR-TFH/TR-TFHS	9
Heavy Duty Stud - TR-HFH/TR-HFHS	6	Heavy Duty Thin Sheet Stud - TR-HFE	10

Nuts

Nut - TR-S/TR-CLS/TR-CLA/TR-SP4/TR-SP2	11-12	Nylon Lock Nut - TR-PL/TR-PLC	19
Flush Nut - TR-F/TR-F4	13	Non-Locking Mini Nut - TR-U/TR-FEX/TR-FEOX	20
Blind Nut - TR-B/TR-BS	14	Self-Locking Mini Squeezed Nut - TR-UL/TR-FE/TR-FEO	21
Broaching Nut - TR-KF2/TR-KFS2	15	Thin Sheet Nut - TR-SMPS	22
Non-Locking Floating Nut - TR-AS/TR-AC	16	Nylon Broaching Nut - TR-CFN	23
Locking Floating Nut - TR-LAS/TR-LAC	17	Thread Lock Feature Nut - TR-SL	24
Locking Nut - TR-LK/TR-LKS	18	Non-Locking H Nut - TR-H	25

Standoffs

Blind Standoff - TR-BSO/TR-BSOS/TR-BSOA/TR-BSO4	26	Grounding Standoff - TR-SOSG	32
Through Standoff - TR-SO/TR-SOS/TR-SOA/TR-SO4	27	Clip-on Standoff - TR-SSS/TR-SSC/TR-SSA	33
Concealed Head Standoff - 1.6mm Sheet - TR-CSS	28	Broaching Through Hole Standoff - TR-KFE/TR-KFSE	34
Concealed Head Standoff - 2.4mm Sheet - TR-CSOS	29	Broaching Threaded Standoff - TR-KFE/TR-KFSE	35
Hole Slide Standoff - TR-SKC	30	Thin Sheet Standoff - TR-TSO/TR-TSOS	36
Close To Edge Standoff - TR-DSO/TR-DSOS	31	Clear Hole Standoff - TR-SO	37

Panel Fasteners

Slotted Panel Fastener - TR-PFS2/TR-PFC2	38	Captive Panel Screw - TR-PF11	42
Cross Recess Panel Fastener - TR-PFC2P	39	Captive Panel Screw - TR-PFHV	43
Low Profile Panel Fastener - TR-PF31/TR-PF32	40	Low Profile Cross Recess Panel Fastener - TR-PF50	44
Pin Panel Fastener - TR-PTL2/TR-PSL2	41		

Pins

Flush Head Pin - TR-TP/TR-TPS/TR-TP4	45	Terminal Pin - TR-TER	46
--------------------------------------	----	-----------------------	----

Cable Tie Mounts

Cable Tie Mount - TR-TD	47
-------------------------	----

www.trfastenings.com

All data is correct to the best of our knowledge, however TR cannot be held responsible for any errors or omissions.

Flush Head Stud TR-FH/TR-FHS/TR-FHA/TR-FH4

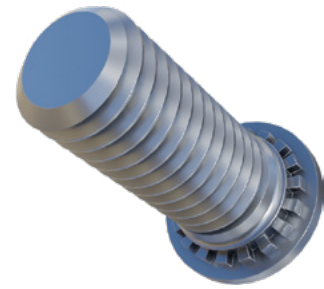
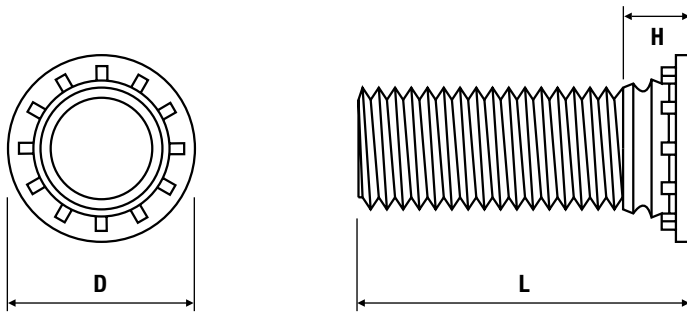

Metric Dimensions

Zinc Plated Steel: TR-FH | Stainless Steel: TR-FHS | Aluminium: TR-FHA | 400 Series Stainless Steel: TR-FH4

Thread	M2	M2.5	M3	M3.5	M4	M5	M6	M8
D ±0.4	3.5	4.1	4.6	5.3	5.9	6.5	8.2	9.6
H max.	1.95	1.95	2.1	2.2	2.4	2.7	3.0	3.7
Min. sheet thickness	1.0	1.0	1.0	1.0	1.0	1.0	1.6	2.4
Recommended hole size +0.08	2.0	2.5	3.0	3.5	4.0	5.0	6.0	8.0
Min. distance to edge of sheet	5.2	5.4	5.6	6.4	7.2	7.2	7.9	9.6

Length (L) ±0.4	5	6	8	10	12	15	16	18	20	22	25	28	30	35	38	40	45	50

Metric Performance Data

Thread		M2	M2.5	M3	M3.5	M4	M5	M6	M8
Test sheet material	TR-FH4	Stainless steel							
	TR-FHS	Steel							
	TR-FH	Steel							
Installation (kN)	TR-FH4	-	40.0	41.0	-	51.0	54.0	71.0	73.5
	TR-FHS	13.5	13.5	14.7	-	26.0	32.0	44.0	49.9
	TR-FH	9.0	11.0	14.7	22.3	28.0	33.5	45.0	45.0
Push-out (N)	TR-FH4	-	-	2230	-	3300	3600	4210	-
	TR-FHS	700	740	820	1335	1790	2000	2500	2800
	TR-FH	700	740	820	1335	1800	2100	2600	2900
Torque-out (Nm)	TR-FH4	-	1.4	1.8	-	6.6	10.8	15.9	-
	TR-FHS	0.45	0.8	1.4	2.0	2.9	6.4	10.0	17.0
	TR-FH	0.45	1.0	1.7	2.8	4.3	6.8	12.0	19.5
Pull through (N)	TR-FH4	-	-	3300	-	8010	10020	14950	-
	TR-FHS	-	1800	2450	-	4800	6000	10600	13600
	TR-FH	1700	2700	3900	3780	5700	6300	11400	15500

TR-FH - Recommended for use in sheet hardness: HRB 80 or less
 TR-FHS - Recommended for use in sheet hardness: HRB 70 or less

TR-FHA - Recommended for use in sheet hardness: HRB 50 or less
 TR-FH4 - Recommended for use in sheet hardness: HRB 92 or less

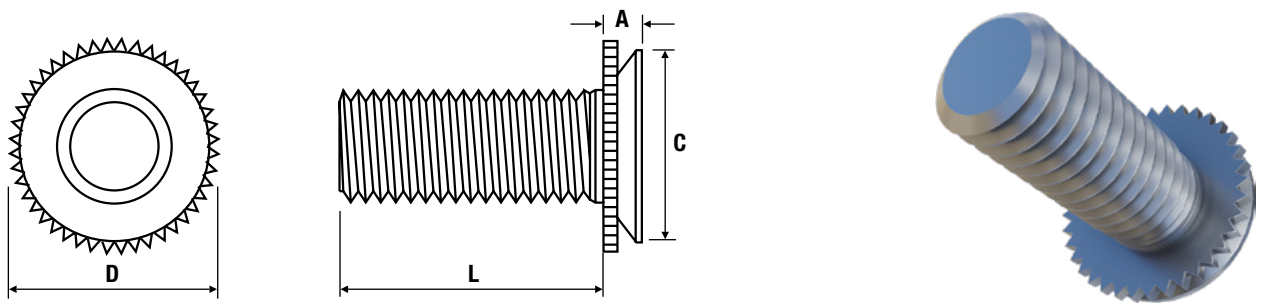

Metric Dimensions

Stainless Steel: TR-CHC | Aluminium: TR-CHA

Thread	M3	M4	M5
D ± 0.4	5.21	8.33	8.89
C max.	4.35	7.35	7.9
Blind mounting hole ± 0.08	4.37	7.37	7.93
Min. distance to edge of sheet	4.0	5.6	6.4
Hole depth	1.10		
A max.	1.04		
Min. sheet thickness	1.60		

Length (L) ± 0.4	6	8	10	12	20	25

Metric Performance Data (TR-CHC)

Thread	M3	M4	M5
Test sheet material	Steel		
Installation (kN)	8.0	17.8	22.2
Pull-out (N)	1065	1200	1290
Max. tightening torque (Nm)	0.5	2.0	3.6

Metric Performance Data (TR-CHA)

Thread	M3	M4	M5
Test sheet material	Aluminium		
Installation (kN)	6.2	12.5	17.8
Pull-out (N)	555	645	755
Max. tightening torque (Nm)	0.3	1.2	2.2

TR-CHC - Recommended for use in sheet hardness: HRB 70 or less
 TR-CHA - Recommended for use in sheet hardness: HRB 50 or less

Concealed Head Stud - 2.4mm Sheet TR-CFHC/TR-CFHA

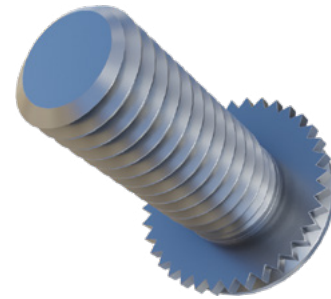
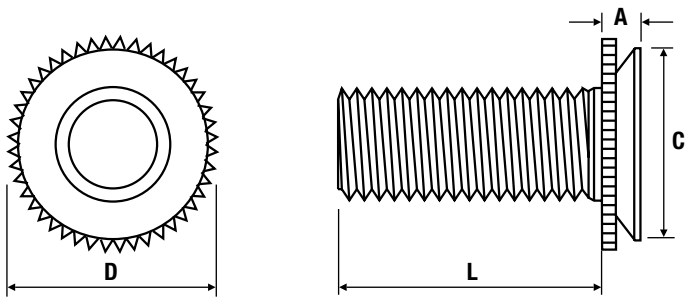

Metric Dimensions

Stainless Steel: TR-CFHC | Aluminium: TR-CFHA

Thread	M3	M4	M5
D ±0.4	5.21	8.33	8.89
C max.	4.35	7.35	7.9
Blind mounting hole ±0.08	4.37	7.37	7.93
Min. distance to edge of sheet	4.0	5.6	6.4
Hole depth	1.91		
A max.	1.83		
Min. sheet thickness	2.40		

Length (L) ±0.4	6	8	10	12	20	25

Metric Performance Data (TR-CFHC)

Thread	M3	M4	M5
Test sheet material	Steel		
Installation (kN)	8.9	14.7	17.8
Pull-out (N)	1065	1955	3020
Max. tightening torque (Nm)	0.5	2.0	3.6

Metric Performance Data (TR-CFHA)

Thread	M3	M4	M5
Test sheet material	Aluminium		
Installation (kN)	6.7	13.3	15.6
Pull-out (N)	845	1065	1330
Max. tightening torque (Nm)	0.3	1.2	2.2

TR-CFHC - Recommended for use in sheet hardness: HRB 70 or less
 TR-CFHA - Recommended for use in sheet hardness: HRB 50 or less

Heavy Duty Stud TR-HFH/TR-HFHS

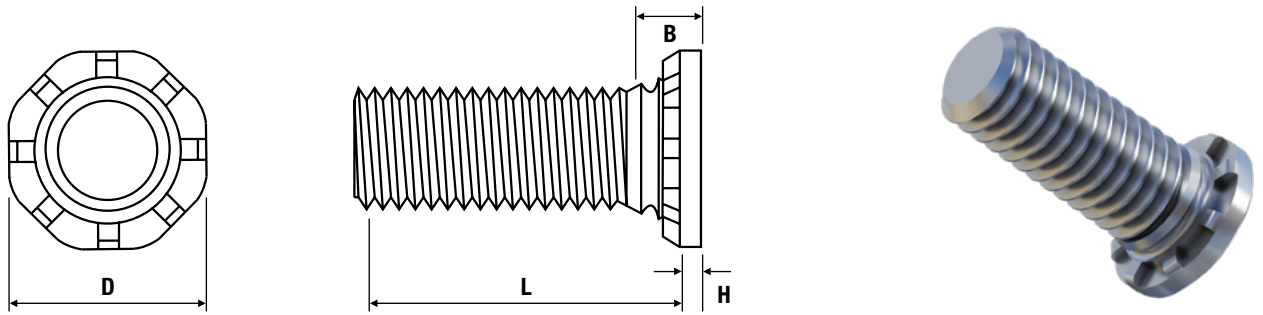

Metric Dimensions

Zinc Plated Steel: TR-HFH | Stainless Steel: TR-HFHS

Thread	M5	M6	M8	M10
D ± 0.25	7.8	9.4	12.5	15.7
B max.	2.7	2.8	3.5	4.1
H max.	1.14	1.27	1.78	2.29
Min. sheet thickness	1.3	1.5	2.0	2.3
Recommended hole size +0.13	5.0	6.0	8.0	10.0
Min. distance to edge of sheet	10.7	11.5	12.7	13.7

Length (L) ± 0.4	10	12	15	16	18	20	25	30	35	40	50

Metric Performance Data

Thread	M5	M6	M8	M10	
Test sheet material	Steel				
Installation (kN)	TR-HFH	27	34	45	55
	TR-HFHS	22.5	25	38	47
Push-out (N)	TR-HFH	1550	1780	2210	3475
	TR-HFHS	1505	1780	2200	3500
Torque-out (Nm)	TR-HFH	7.7	14.5	30.1	49.5
	TR-HFHS	6.5	11.5	21	36.5

TR-HFH - Recommended for use in sheet hardness: HRB 85 or less

TR-HFHS - Recommended for use in sheet hardness: HRB 70 or less

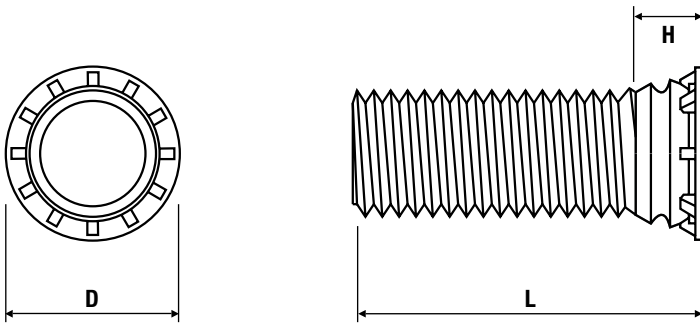

Metric Dimensions

Zinc Plated Steel: TR-FHL | Stainless Steel: TR-FHLS

Thread	M2.5	M3	M4	M5
D ± 0.4	3.15	3.65	4.65	5.9
H max.	2.1	2.1	2.4	2.7
Min. sheet thickness	1.0			
Recommended hole size +0.08	2.5	3.0	4.0	5.0
Min. distance to edge of sheet	2.8	3.3	4.3	5.6

Length (L) ± 0.4	6	8	10	12	15	18	20	25	30

Metric Performance Data

Thread	M2.5	M3	M4	M5
Test sheet material	Steel			
Test sheet thickness	1.1	1.1	1.1	1.1
Installation (kN)	5.4	5.4	6.7	20.1
Push-out (N)	450	475	555	1010
Torque-out (Nm)	1.2	1.3	2.2	4.5
Pull through (N)	2290	2550	3350	3760

TR-FHL - Recommended for use in sheet hardness: HRB 80 or less

TR-FHLS - Recommended for use in sheet hardness: HRB 70 or less

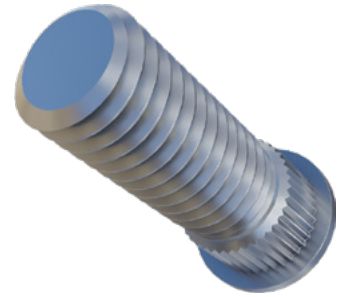
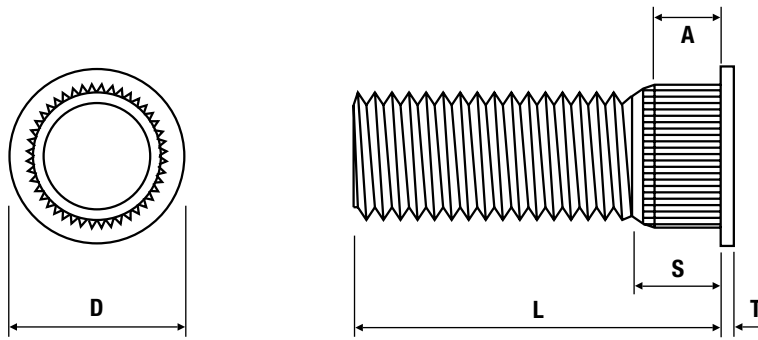

Metric Dimensions

Electro-Tin Plated Phosphor Bronze: TR-KFH

Thread	M2.5	M3	M4	M5
D ±0.25	4.10	4.58	5.74	6.6
S max.	2.3	2.3	2.3	2.3
A max.	1.65	1.65	1.65	1.65
T ±0.13	0.51	0.51	0.51	0.51
Min. sheet thickness	1.53	1.53	1.53	1.53
Recommended hole size +0.08	2.6	3.0	4.2	5.0
Min. distance to edge of sheet	3.3	3.8	5.1	5.3

Length (L) ±0.4	6	8	10	12	15

TR-KFH - Recommended for use in sheet hardness: HRB 55 or less

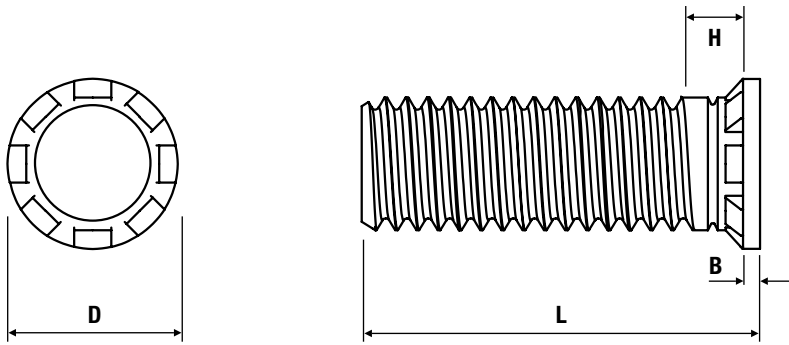

Metric Dimensions

Zinc Plated Steel: TR-TFH | Stainless Steel: TR-TFHS

Thread	M3	M4	M5
D ± 0.25	4.5	5.8	6.4
H max.	1.8	1.8	2.3
B max.	0.64	0.64	0.64
Min. sheet thickness	0.51	0.51	0.51
Recommended hole size $+0.08$	3.0	4.0	5.0

Length (L) ± 0.4	6	8	10	12	15	18	20	25	30	35

Metric Performance Data

Thread		M3	M4	M5
Test sheet material		Steel		
Installation (kN)	TR-TFH	7.9	17.8	22.1
	TR-TFHS	6.7	13.4	12.9
Push-out (N)	TR-TFH	410	450	550
	TR-TFHS	390	465	580
Torque-out (Nm)	TR-TFH	1.3	2.0	2.7
	TR-TFHS	0.8	2.5	3.0

TR-TFH - Recommended for use in sheet hardness: HRB 80 or less

TR-TFHS - Recommended for use in sheet hardness: HRB 70 or less

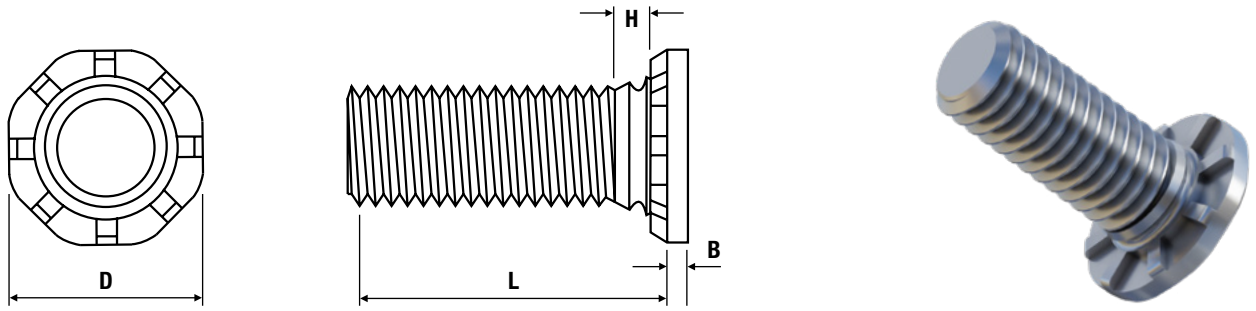

Metric Dimensions

Zinc Plated Steel: TR-HFE

Thread	M5	M6	M8
D ± 0.25	9.60	11.35	15.30
H max.	2.60	2.80	3.30
B max.	1.35	1.52	2.13
Min. sheet thickness	1.0	1.0	1.5
Recommended hole size +0.13	5.0	6.0	8.0
Min. distance to edge of sheet	10.00	11.50	14.50

Length (L) ± 0.4	8	15	18	20	25	30	35	40	50

Metric Performance Data

Thread	M5	M6	M8
Test sheet material	Steel		
Max. nut tightening torque (Nm)	6.4	11.0	26.0
Installation (kN)	51.1	60.0	71.1
Push-out (N)	1350	1400	2400
Torque-out (Nm)	8.1	14.4	33.9
Tensile strength (kN)	12.8	18.1	32.9
Pull through (kN)	10.6	15.5	27.5
Bushing hole size for pull through (mm)	7.4	8.2	10.3

TR-HFE - Recommended for use in sheet hardness: HRB 85 or less

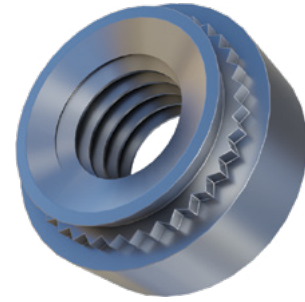
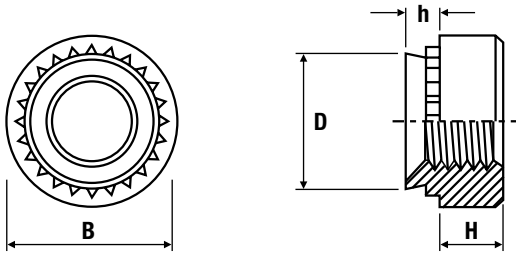

Metric Dimensions (TR-S/TR-CLS/TR-SP4/TR-SP2)

Zinc Plated Steel: TR-S | Stainless Steel: TR-CLS | Aluminium: TR-CLA
400 Series Stainless Steel: TR-SP4 | A286 Stainless Steel: TR-SP2

Thread	M2, M2.5, M3			M3alt			M3.5			M4			
	0	1	2	0	1	2	0	1	2	0	1	2	3
D max.	4.20			4.73			4.73			5.38			
B ±0.2	6.35			7.1			7.1			7.95			
H ±0.25	1.5			1.5			1.5			2.0			
h max.	0.77	0.97	1.38	0.77	0.97	1.38	0.77	0.97	1.38	0.77	0.97	1.38	2.21
Min. sheet thickness	0.8	1.0	1.4	0.8	1.0	1.4	0.8	1.0	1.4	0.8	1.0	1.4	2.3
Recommended hole size +0.08	4.22			4.75			4.75			5.41			
Min. distance to edge of sheet	4.8			5.6			5.6			6.9			

Thread	M5				M6				M8			M10		M12	
	0	1	2	3	00	0	1	2	3	1	2	3	1	2	1
D max.	6.33				8.73				10.47			13.97		16.95	
B ±0.2	8.75				11.10				12.65			17.35		20.55	
H ±0.25	2.0				4.08				5.47			7.48		8.5	
h max.	0.77	0.97	1.38	2.21	0.89	1.15	1.38	2.21	3.05	1.38	2.21	3.05	2.21	3.05	3.05
Min. sheet thickness	0.8	1.0	1.4	2.3	0.92	1.2	1.4	2.3	3.2	1.4	2.3	3.2	2.3	3.2	3.2
Recommended hole size +0.08	6.35				8.75				10.5			14.0		17.0	
Min. distance to edge of sheet	7.1				8.6				9.7			13.5		16.0	

Metric Dimensions (TR-CLA)

Thread	M2		M3		M3.5		M4		M5		M6	
	1	2	1	2	1	2	1	2	1	2	1	2
D max.	4.22		4.73		5.38		5.97		7.47		8.72	
B ±0.2	6.3		6.3		7.1		7.9		9.5		11.05	
H ±0.25	1.5		2.0		2.0		3.0		3.8		4.08	
h max.	0.98	1.38	0.98	1.38	0.98	1.38	0.98	1.38	0.98	1.38	1.38	2.21
Min. sheet thickness	1.0	1.4	1.0	1.4	1.0	1.4	1.0	1.4	1.0	1.4	1.4	2.3
Recommended hole size +0.08	4.25		4.75		5.4		6.0		7.5		8.75	
Min. distance to edge of sheet	4.8		5.6		6.9		7.1		7.9		8.6	



Metric Performance Data (TR-S/TR-CLS)

Thread	M2, M2.5			M3				M3alt			M3.5			M4			
Test material	Steel																
Shank code	0	1	2	0	1	2	3	0	1	2	0	1	2	0	1	2	3
Installation (kN)	11.2 - 15.6			11.2 - 15.6				13.4 - 26.7			13.4 - 26.7			18 - 27			
Torque-out (Nm)	1.5	1.75	2.0	1.5	1.75	2.0	2.1	1.8	2.4	2.4	1.8	2.4	2.4	3.0	4.0	5.0	4.2
Push-out (N)	480	560	1020	480	560	1020	1110	485	575	1200	485	575	1200	495	650	1255	1300

Thread	M5				M6			M8			M10		M12	
Test material	Steel													
Shank code	0	1	2	3	1	2	3	1	2	3	1	2	1	
Installation (kN)	18 - 38				27 - 36			27 - 36			32 - 50		33 - 49	
Torque-out (Nm)	3.7	4.5	6.9	6.0	17.1	17.1	16.4	18.8	20.4	18.1	36.1	36.1	73.9	
Push-out (N)	535	801	1115	1500	1765	1765	1755	1870	1870	1860	2021	2021	3065	

TR-S - Recommended for use in sheet hardness: HRB 80 or less
 TR-CLS - Recommended for use in sheet hardness: HRB 70 or less

TR-CLA - Recommended for use in sheet hardness: HRB 50 or less
 TR-SP4/SP2 - Recommended for use in sheet hardness: HRB 90 or less

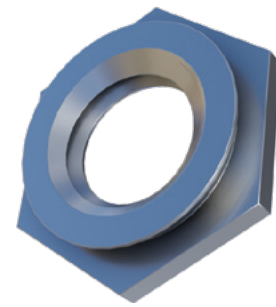
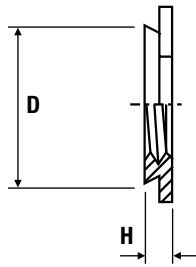
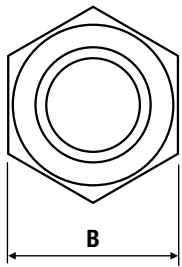

Metric Dimensions

Stainless Steel: TR-F | 400 Series Stainless Steel TR-F4

Thread	M2, M2.5		M3		M3alt		M3.5		M4		M5		M6		
Shank code	1	2	1	2	1	2	1	2	1	2	1	2	3	4	5
D max.	4.35		4.35		5.35		5.35		7.35		7.90		8.72		
B nom.	4.8		4.8		6.4		6.4		7.9		8.7		9.5		
H max.	1.53	2.3	1.53	2.3	1.53	2.3	1.53	2.3	1.53	2.3	1.53	2.3	3.05	3.84	4.63
Sheet thickness	1.53 - 2.3	2.32 min.	1.53 - 2.3	2.32 min.	1.53 - 2.3	2.32 min.	1.53 - 2.3	2.32 min.	1.53 - 2.3	2.32 min.	1.53 - 2.3	2.32 min.	3.18 - 3.94	3.96 - 4.72	4.75 min.
Recommended hole size +0.08	4.37		4.37		5.4		5.4		7.37		7.92		8.74		
Min. distance to edge of sheet	6.0		6.0		6.5		6.5		7.2		8.0		8.8		

Metric Performance Data (TR-F)

Thread	M2, M2.5		M3		M3alt		M3.5		M4		M5		M6		
Shank code	1	2	1	2	1	2	1	2	1	2	1	2	3	4	5
Test sheet material	Steel														
Test sheet thickness	1.5	2.3	1.5	2.3	1.5	2.3	1.5	2.3	1.5	2.3	1.5	2.3	3.1	3.9	4.75
Installation (kN)	13.5		13.5		13.5		13.5		18.0		22.0		26.5		
Push-out (N)	900		900		1100		1100		1060		1060		3700		

Metric Performance Data (TR-F4)

Thread	M2, M2.5		M3		M4		M5		M6		
Shank code	1	2	1	2	1	2	1	2	3	4	5
Test sheet material	300 series stainless steel										
Test sheet thickness	1.5	2.3	1.5	2.3	1.5	2.3	1.5	2.3	3.1	3.9	4.75
Installation (kN)	32		32		40		40		65		
Push-out (N)	1200		1200		2000		2000		4500		

TR-F - Recommended for use in sheet hardness: HRB 70 or less

TR-F4 - Recommended for use in sheet hardness: HRB 80 or less

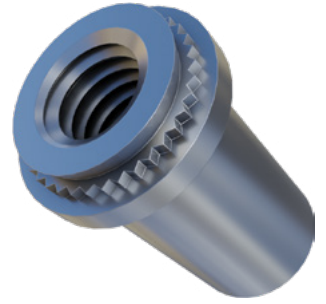
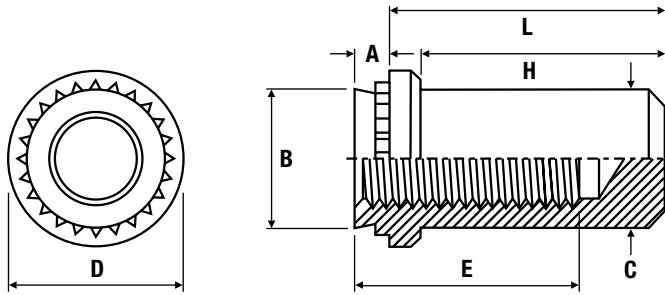

Metric Dimensions

Zinc Plated Steel: TR-B | Stainless Steel: TR-BS

Thread	M3		M4		M5		M6	
Shank code	1	2	1	2	1	2	1	2
A max.	0.97	1.38	0.97	1.38	0.97	1.38	1.38	2.21
Min. sheet thickness	1.0	1.4	1.0	1.4	1.0	1.4	1.4	2.29
Recommended hole size +0.08	4.22		5.41		6.35		8.75	
B max.	4.20		5.38		6.33		8.73	
C max.	3.84		5.2		6.02		7.8	
D ±0.25	6.35		7.95		8.75		11.1	
E min.	5.3		7.1		7.1		7.8	
L max.	9.6		11.2		11.2		14.3	
H ±0.25	8.5		9.8		9.8		12.7	
Min. distance to edge of sheet	4.8		6.9		7.1		8.6	

Metric Performance Data

Thread	M3		M4		M5		M6	
Shank code	1	2	1	2	1	2	1	2
Test sheet material	Steel							
Sheet thickness	1.0	1.4	1.0	1.4	1.0	1.4	1.4	2.3
Installation (kN)	11.5	14.0	16.0	21.0	18.0	25.0	26.0	26.0
Push-out (N)	572	1020	605	1256	630	1110	1782	1782
Torque-out (Nm)	1.7	2.15	3.5	5.1	4.1	6.9	11.9	11.9

TR-B - Recommended for use in sheet hardness: HRB 80 or less
 TR-BS - Recommended for use in sheet hardness: HRB 70 or less

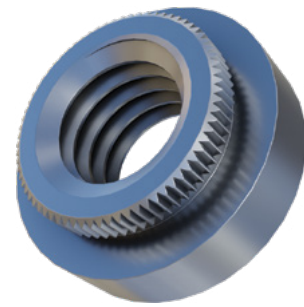
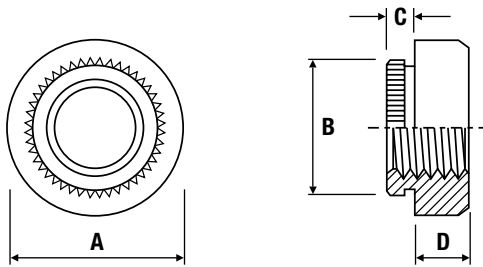

Metric Dimensions

Electro Tin Plated Steel: TR-KF2 | Stainless Steel: TR-KFS2

Thread	M2	M2.5	M3	M3.5	M4	M5
C max.	1.53	1.53	1.53	1.53	1.53	1.53
B ±0.08	4.19	4.68	4.68	5.88	6.86	7.37
A ±0.13	5.56	5.56	5.56	7.0	8.74	9.53
D ±0.13	1.5	1.5	1.5	1.6	2.0	3.0
Min. sheet thickness	1.53	1.53	1.53	1.53	1.53	1.53
Recommended hole size +0.08	3.73	4.22	4.22	5.5	6.40	6.90
Min. distance to edge of sheet	4.2	4.4	4.4	5.5	6.4	7.1

Metric Performance Data

Thread	M2	M2.5	M3	M3.5	M4	M5
Test sheet material	FR4 fibreglass					
Test sheet thickness	1.5					
Installation (kN)	2.2	2.2	2.2	2.2	2.2	2.9
Torque-out (Nm)	0.70	0.70	1.70	1.70	3.40	4.55
Push-out (N)	260	260	290	290	420	440

TR-KF2 - Recommended for use in sheet hardness: HRB 60 or less

TR-KFS2 - Recommended for use in sheet hardness: HRB 70 or less

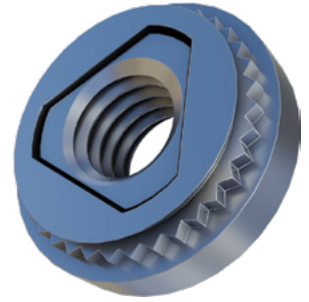
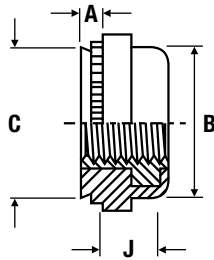
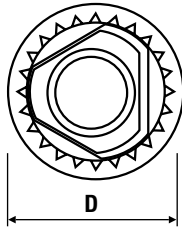

Metric Dimensions

Zinc Plated Steel: TR-AS | Stainless Steel: TR-AC

Thread	M3		M4		M5		M6
Shank code	1	2	1	2	1	2	2
A max.	0.97	1.38	0.97	1.38	0.97	1.38	1.38
Min. sheet thickness	0.97	1.38	0.97	1.38	0.97	1.38	1.38
Recommended hole size +0.08	7.37		9.35		10.31		13.08
B max.	7.35		9.33		10.29		13.06
C max.	7.37		9.28		10.29		12.96
D ±0.4	9.14		11.18		11.94		15.24
J max.	3.31		3.31		4.32		5.34
Min. distance to edge of sheet	7.62		8.64		9.14		10.67

Metric Performance Data

Thread	M3		M4		M5		M6
Shank code	1	2	1	2	1	2	2
Test sheet material	Steel						
Installation (kN)	13.3	13.3	13.3	13.3	15.6	15.6	22.2
Push-out (N)	1340	1340	1340	1784	1789	2009	2226
Torque-out (Nm)	9.7	17.0	17.0	22.8	17.0	22.9	36.9

TR-AS - Recommended for use in sheet hardness: HRB 70 or less

TR-AC - Recommended for use in sheet hardness: HRB 70 or less

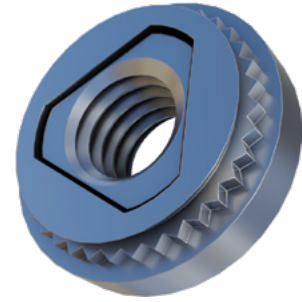
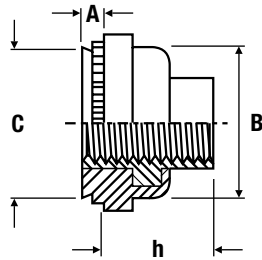
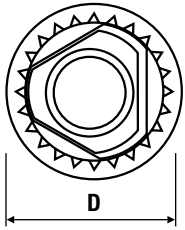

Metric Dimensions

Zinc Plated Steel: TR-LAS | Stainless Steel: TR-LAC

Thread	M3		M4		M5		M6
	1	2	1	2	1	2	2
Shank code	1	2	1	2	1	2	2
A max.	0.97	1.38	0.97	1.38	0.97	1.38	1.38
Min. sheet thickness	0.97	1.38	0.97	1.38	0.97	1.38	1.38
Recommended hole size +0.08	7.37		9.35		10.31		13.08
B max.	7.35		9.33		10.29		13.06
C max.	7.37		9.28		10.29		12.96
D ±0.4	9.14		11.18		11.94		15.24
h max.	4.83		5.34		6.86		7.88
Min. distance to edge of sheet	7.62		8.64		9.14		10.67

Metric Performance Data

Thread	M3		M4		M5		M6
	1	2	1	2	1	2	2
Test sheet material	Steel						
Installation (kN)	13.3	13.3	13.3	13.3	15.6	15.6	22.2
Push-out (N)	1340	1340	1340	1784	1789	2009	2226
Torque-out (Nm)	9.7	17.0	17.1	22.8	16.9	22.9	36.9

TR-LAS - Recommended for use in sheet hardness: HRB 70 or less

TR-LAC - Recommended for use in sheet hardness: HRB 70 or less

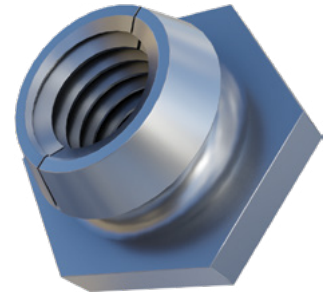
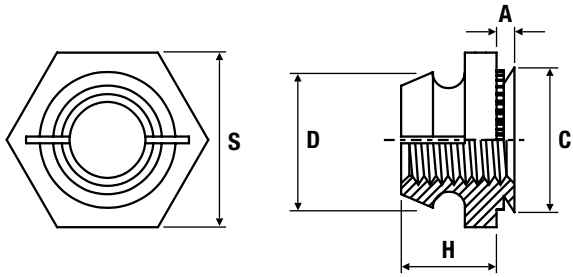

Metric Dimensions

Zinc Plated Steel: TR-LK | Stainless Steel: TR-LKS

Thread	M2.5		M3		M4		M5	
Shank code	1	2	1	2	1	2	1	2
A shank max.	0.97	1.38	0.97	1.38	0.97	1.38	0.97	1.38
Min. sheet thickness	1.0	1.4	1.0	1.4	1.0	1.4	1.0	1.4
Recommended hole size +0.08	4.37		4.75		6.76		7.92	
C max.	4.35		4.73		6.73		7.90	
D max.	4.45		4.85		6.20		7.40	
S nom.	6.35		6.35		8.73		9.53	
H ±0.25	3.43		3.43		4.45		5.21	
Min. distance to edge of sheet	3.90		4.00		5.20		5.60	

Metric Performance Data

Thread	M2.5		M3		M4		M5	
Shank code	1	2	1	2	1	2	1	2
Test sheet material	Steel							
Installation (kN)	13.3	13.3	13.3	13.3	17.8	19.1	17.8	19.1
Push-out (N)	667	711	667	1112	845	1334	1112	1334
Torque-out (Nm)	2.3	2.3	3.4	4.5	5.6	7.9	11.3	13.6

TR-LK - Recommended for use in sheet hardness: HRB 70 or less

TR-LKS - Recommended for use in sheet hardness: HRB 70 or less

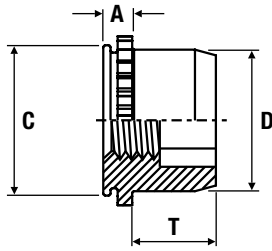
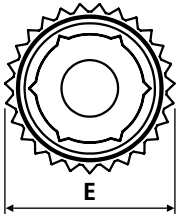

Metric Dimensions

Zinc Plated Steel: TR-PL | Stainless Steel: TR-PLC

Thread	M3	M4	M5
A max.	1.53	1.53	1.53
Sheet thickness	1.0 - 1.78	1.0 - 1.78	1.0 - 1.78
Recommended hole size +0.08	6.0	7.5	8.0
C max.	5.98	7.48	7.98
D max.	5.52	7.01	7.52
E max.	7.01	8.54	9.0
T max.	3.56	4.2	4.45
Min. distance to edge of sheet	4.32	5.59	6.35
Max. hole in attached parts	3.5	4.5	5.5

Metric Performance Data

Thread	M3	M4	M5
Test sheet material	Steel		
Installation (kN)	13.34	13.34	13.34
Push-out (N)	1156	1290	1557
Torque-out (Nm)	2.25	6.77	7.90

TR-PL - Recommended for use in sheet hardness: HRB 70 or less
 TR-PLC - Recommended for use in sheet hardness: HRB 70 or less

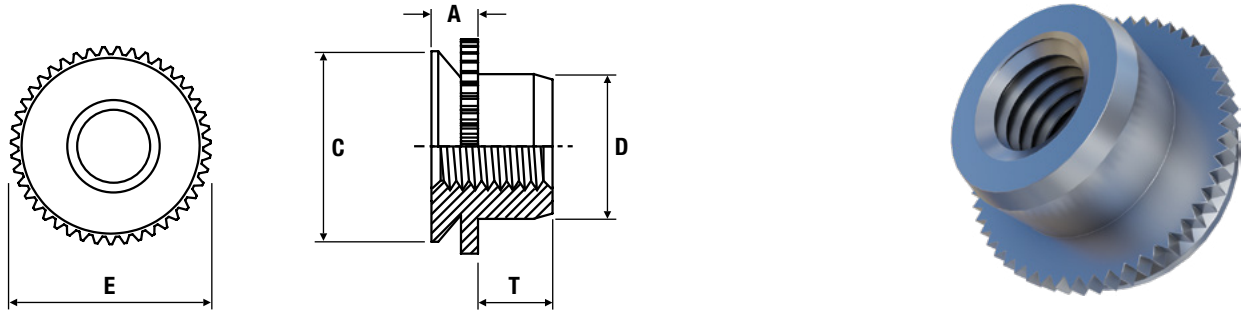

Metric Dimensions (TR-U)

Stainless Steel: TR-U/TR-FEX/TR-FEOX

Thread	M2
E ±0.13	4.07
A (shank) max.	0.79
C -0.13	3.60
D max.	2.50
T +0.4	1.65
Sheet thickness	0.76 - 0.91
Recommended hole size +0.08	3.61
Min. distance to edge of sheet	2.80

Metric Dimensions (TR-FEX/TR-FEOX)

Thread		M3	M4	M5	M6
E ±0.13		4.88	8.17	8.17	9.74
A (shank) max.	FEX	1.53	1.53	1.53	1.53
	FEOX	1.02	1.02	1.02	1.02
C -0.13		4.37	7.37	7.37	8.72
D max.		3.96	5.23	6.48	7.72
T +0.4		1.9	2.55	3.05	3.3
Sheet thickness	FEX	1.5 - 1.78	1.5 - 1.78	1.5 - 1.78	1.5 - 1.78
	FEOX	0.99 - 1.14	0.99 - 1.14	0.99 - 1.14	0.99 - 1.14
Hole size in sheet +0.08		4.39	7.39	7.39	8.74
Min. distance to edge of sheet		3.6	5.2	5.2	7.1

TR-U - Recommended for use in sheet hardness: HRB 70 or less
 TR-FEX - Recommended for use in sheet hardness: HRB 70 or less

TR-FEOX - Recommended for use in sheet hardness: HRB 70 or less

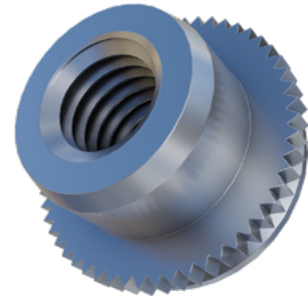
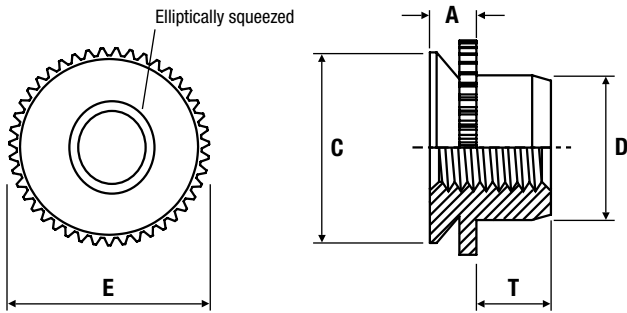

Metric Dimensions (TR-UL)

Stainless Steel: TR-UL/TR-FE/TR-FEO

Thread	M2
E ±0.13	4.07
A (shank) max.	0.76
C -0.13	3.60
D max.	2.50
T +0.4	1.65
Sheet thickness	0.76 - 0.91
Recommended hole size +0.08	3.61
Min. distance to edge of sheet	2.80

Metric Dimensions (TR-FE/TR-FEO)

Thread		M3	M4	M5	M6
E ±0.13		4.88	8.17	8.17	9.74
A (shank) max.	FE	1.53	1.53	1.53	1.53
	FEO	1.02	1.02	1.02	1.02
C -0.13		4.37	7.37	7.37	8.72
D max.		3.96	5.23	6.48	7.72
T +0.4		1.9	2.55	3.05	3.3
Sheet thickness	FE	1.5 - 1.78	1.5 - 1.78	1.5 - 1.78	1.5 - 1.78
	FEO	0.99 - 1.14	0.99 - 1.14	0.99 - 1.14	0.99 - 1.14
Hole size in sheet +0.08		4.39	7.39	7.39	8.74
Min. distance to edge of sheet		3.6	5.2	5.2	7.1

TR-U - Recommended for use in sheet hardness: HRB 70 or less
 TR-FE - Recommended for use in sheet hardness: HRB 70 or less

TR-FEO - Recommended for use in sheet hardness: HRB 70 or less

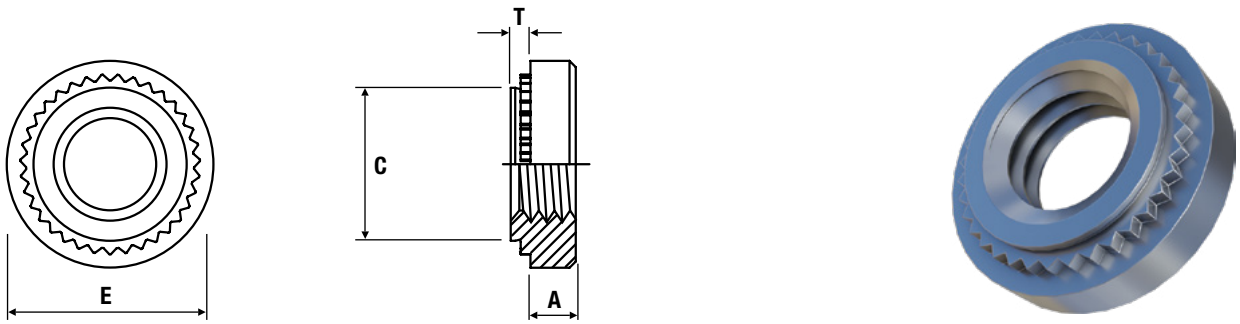

Metric Dimensions

300 Series Stainless Steel: TR-SMPS

Thread	M2.5	M3	M3.5
A shank max.	0.61		
Min. sheet thickness	0.64		
Recommended hole size +0.08	3.8	4.24	4.75
C max.	3.79	4.22	4.73
E ±0.25	5.6	5.6	6.4
T ±0.25	1.4		
Min. distance to edge of sheet	3.7	4.3	5.1

Metric Performance Data

Thread	M2.5	M3	M3.5
Test sheet material	Steel		
Installation (kN)	6.7	8.0	8.8
Push-out (N)	156	267	289
Torque-out (Nm)	1.13	1.35	1.58

TR-SMPS - Recommended for use in sheet hardness: HRB 70 or less

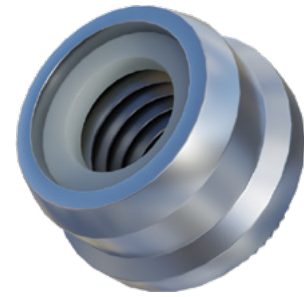
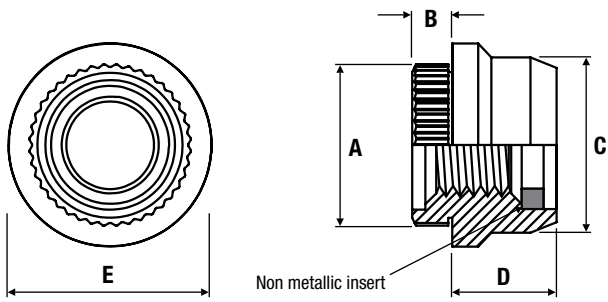

Metric Dimensions

Stainless Steel: TR-CFN

Thread	M3
A	4.11
B	1.02
C	4.45
D	2.65
E max.	5.19
Min. sheet thickness	1.1
Recommended hole size +0.08	3.8
Min. distance to edge of sheet	2.93

Metric Performance Data

Thread	M3
Test sheet material	Steel
Installation (kN)	4.45
Push-out (N)	44.5
Torque-out (Nm)	0.45

TR-CFN - Recommended for use in sheet hardness: HRB 60 or less

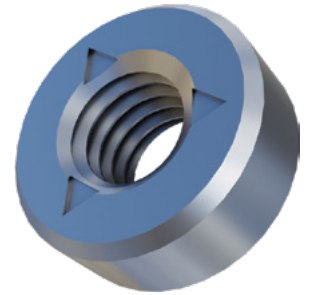
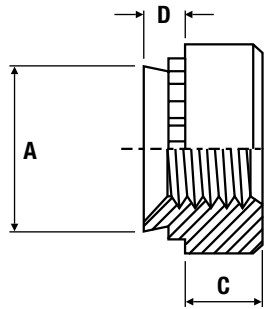
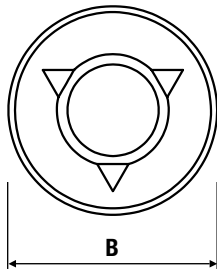

Metric Dimensions

Zinc Plated Steel: TR-SL

Thread	M3		M3.5		M4		M5		M6		M8	
	1	2	1	2	1	2	1	2	1	2	1	2
A	4.2		4.73		5.38		6.33		8.73		10.47	
B	6.35		7.11		7.87		8.64		11.18		12.7	
C	1.5		1.5		2.0		2.0		4.08		5.47	
D	0.98	1.38	0.98	1.38	0.98	1.38	0.98	1.38	1.38	2.21	1.38	2.21
Min. sheet thickness	1.0	1.4	1.0	1.4	1.0	1.4	1.0	1.4	1.4	2.3	1.4	2.3
Recommended hole size +0.08	4.22		4.75		5.41		6.35		8.75		10.5	
Min. distance to edge of sheet	4.8		5.6		6.9		7.1		8.6		9.7	

Metric Performance Data

Thread	M3		M3.5		M4		M5		M6		M8	
	1	2	1	2	1	2	1	2	1	2	1	2
Test sheet material	Steel											
Installation (kN)	11.2 - 15.6		13.4 - 26.7		18.0 - 27.0		18.0 - 38.0		27.0 - 36.0		27.0 - 36.0	
Torque-out (Nm)	1.7	2.03	2.3	2.3	4.0	5.1	4.5	6.8	17.0	17.0	18.7	20.3
Push-out (N)	550	1010	570	1210	645	1250	800	1112	1760	1760	1870	1870

TR-SL - Recommended for use in sheet hardness: HRB 80 or less

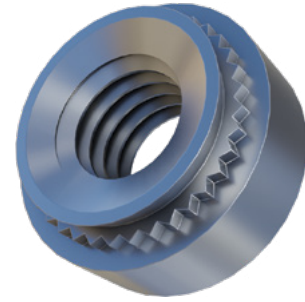
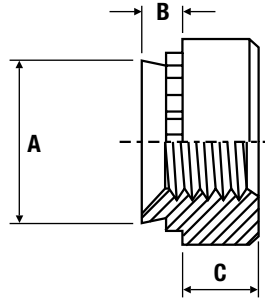
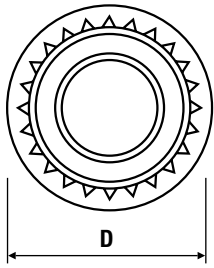

Metric Dimensions

Stainless Steel: TR-H

Thread	M10
A	12.67
B	1.48
C	7.9
D	16.5
Min. sheet thickness	1.48
Recommended hole size +0.08	12.7 - 12.83
Min. distance to edge of sheet	12

Metric Performance Data

Thread	M10
Test sheet material	Steel
Installation (kN)	33
Push-out (N)	2020
Torque-out (Nm)	27.1

TR-H - Recommended for use in sheet hardness: HRB 80 or less

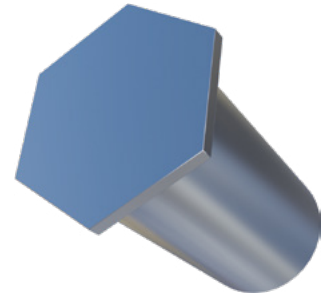
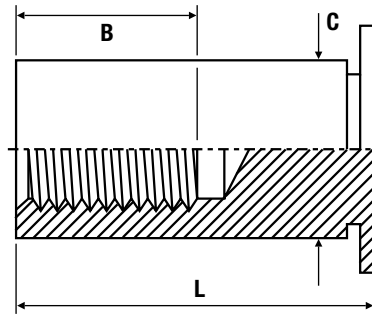
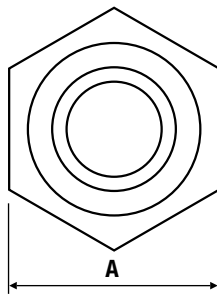

Metric Dimensions

Zinc Plated Steel: TR-BSO | Stainless Steel: TR-BSOS | Aluminium: TR-BSOA | 400 Series Stainless Steel: TR-BSO4

Thread	M2, M2.5, M3	M3alt	M4	M5
C -0.13	4.2	5.39	7.12	7.12
A nom.	4.8	6.4	7.9	7.9
Min. sheet thickness	1.0	1.0	1.27	1.27
Recommended hole size +0.08	4.22	5.41	7.14	7.14
Min. distance to edge of sheet	6.0	6.8	8.0	8.0

(L) Length +0.05/-0.13	5	6	7	8	9	10	12	14	15	16	18	20	22	25
(B) Thread depth - min.	2.8	3.2	3.6	4.0			5.0	6.5			9.5			

Metric Performance Data (TR-BSO/TR-BSOS)

Thread	M2, M2.5, M3	M3alt	M4	M5
Test sheet material	Steel			
Installation (kN)	9.9	14.8	17.9	17.9
Torque-out (Nm)	2.16	3.95	8.5	8.5
Push-out (N)	1050	1870	2500	2500

TR-BSO - Recommended for use in sheet hardness: HRB 80 or less
 TR-BSOS - Recommended for use in sheet hardness: HRB 70 or less

TR-BSOA - Recommended for use in sheet hardness: HRB 50 or less
 TR-BSO4 - Recommended for use in sheet hardness: HRB 88 or less

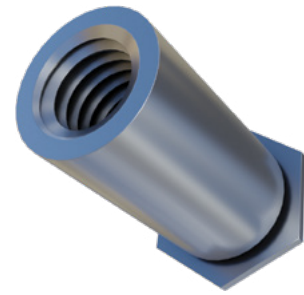
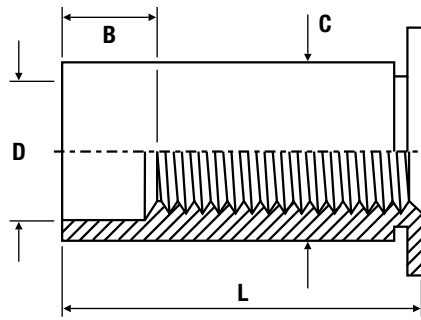
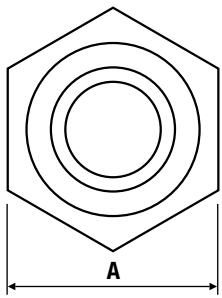

Metric Dimensions

Zinc Plated Steel: TR-SO | Stainless Steel: TR-SOS | Aluminium: TR-SOA | 400 Series Stainless Steel: TR-SO4

Thread	M2, M2.5, M3	M3alt	M4	M5
C -0.13	4.2	5.39	7.12	7.12
D counter-bore diameter -0.13	3.2	3.2	4.8	5.35
A nom.	4.8	6.4	7.9	7.9
Min. sheet thickness	1.0	1.0	1.27	1.27
Recommended hole size +0.08	4.22	5.41	7.14	7.14
Min. distance to edge of sheet	6.0	6.8	8.0	8.0

(L) Length +0.05/-0.13	3	4	5	6	7	8	9	10	12	14	15	16	18	20	22	25
(B) Thread depth - min.	N/A						4			8		11				

Metric Performance Data (TR-SO/TR-SOS)

Thread	M2, M2.5, M3	M3alt	M4	M5
Test sheet material	Steel			
Installation (kN)	9.9	14.8	17.9	17.9
Torque-out (Nm)	2.16	3.95	8.5	8.5
Push-out (N)	1050	1870	2500	2500

TR-SO - Recommended for use in sheet hardness: HRB 80 or less
 TR-SOS - Recommended for use in sheet hardness: HRB 70 or less

TR-SOA - Recommended for use in sheet hardness: HRB 50 or less
 TR-SO4 - Recommended for use in sheet hardness: HRB 88 or less

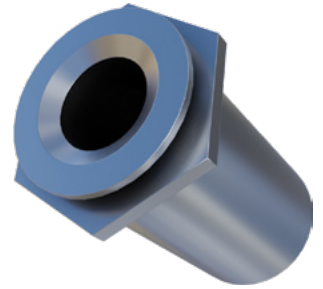
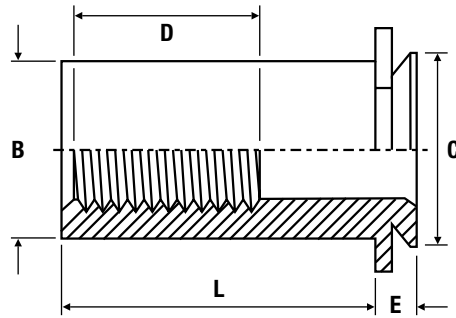
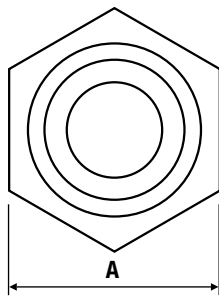

Metric Dimensions

Stainless Steel: TR-CSS

Thread	M3	M4	M5
A	6.35	8.73	9.53
B	4.2	6.23	7.37
C	5.39	7.9	8.72
D	5.0	6.5	9.6
Blind mounting hole ± 0.8	5.41	7.92	8.74
Min. distance to edge of sheet	4.8	6.4	7.2
Hole depth	1.09	1.09	1.09
E min. depth of blind hole	1.04	1.04	1.04
Min. sheet thickness	1.6	1.6	1.6

Length (L) ± 0.13	4	6	8	10	12	16	20

Metric Performance Data

Thread	M3	M4	M5
Test sheet material	Steel		
Installation (kN)	17.8	21.3	24.5
Push-out (N)	1330	1775	2000
Max. tightening torque (Nm)	0.55	2.0	3.6

TR-CSS - Recommended for use in sheet hardness: HRB 70 or less

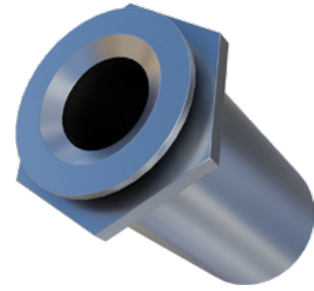
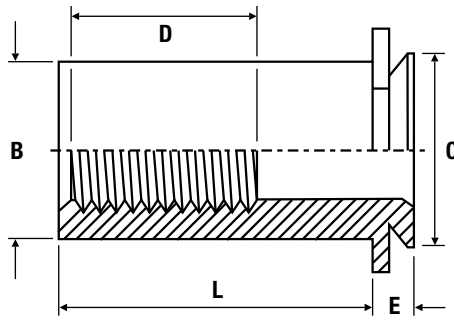
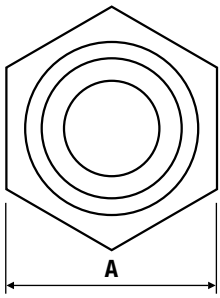

Metric Dimensions

Stainless Steel: TR-CSOS

Thread	M3	M4	M5	M6
A	6.35	8.73	9.53	11.11
B	4.2	6.23	7.37	9.0
C	5.39	7.9	8.72	9.89
D	5.0	6.5	9.6	9.6
Blind mounting hole ± 0.8	5.41	7.92	8.74	9.9
Min. distance to edge of sheet	4.8	6.4	7.2	9.5
Hole depth	1.91	1.91	1.91	1.91
E min. depth of blind hole	1.83	1.83	1.83	1.83
Min. sheet thickness	2.4	2.4	2.4	2.4

Length (L) ± 0.13	4	6	8	10	12	16	20

Metric Performance Data

Thread	M3	M4	M5	M6
Test sheet material	Steel			
Installation (kN)	19.2	23.6	26.7	28.9
Push-out (N)	1465	1955	2665	2860
Max. tightening torque (Nm)	0.55	2.00	3.60	7.20

TR-CSOS - Recommended for use in sheet hardness: HRB 70 or less

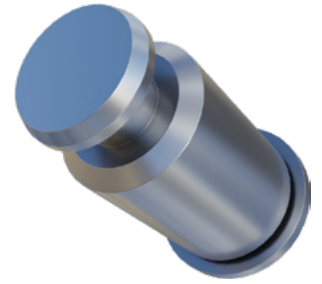
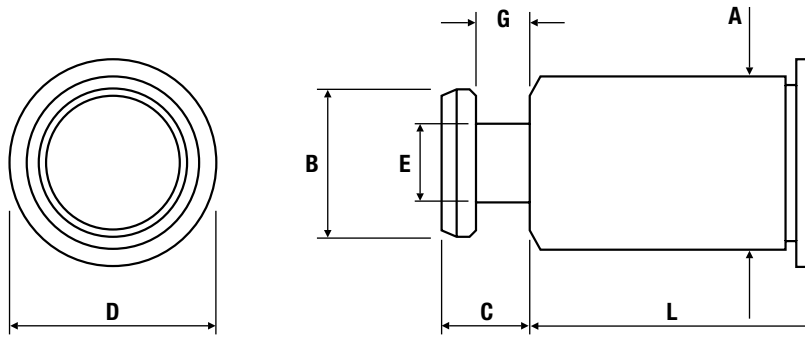

Metric Dimensions

Stainless Steel: TR-SKC

Body size - Sheet code	61.5
A max.	5.39
B ± 0.08	4.5
C max.	2.75
D nom.	6.35
E	2.51
G ± 0.08	1.73
Recommended hole size + 0.08	5.5

Length (L) ± 0.13	2	4	6	8	10	12	14	16	18	20	22	25
-----------------------	---	---	---	---	----	----	----	----	----	----	----	----

Metric Performance Data

Body size - Sheet code	61.5
Test sheet material	Steel
Test sheet thickness	1.52
Installation (kN)	14.3
Push-out (N)	2650

Part number	Panel 1 - Metal HRB50					Panel 2 - PC board or metal					
	Bottom mounting hole +0.08	Max. hardness	Min. thickness	Min. distance to edge of sheet	Max. location tolerance	Top mounting hole +0.08				Thickness range	Min. distance to edge of sheet
						A1 nom.	A2 ± 0.08	A3 ± 0.08	A4 min.		
TR-SKC	5.4	HRB 70	1.0	6.6	± 0.13	1.5	3.0	5.0	3.75	1.45 - 1.62	4.1

TR-SKC - Recommended for use in sheet hardness: HRB 70 or less

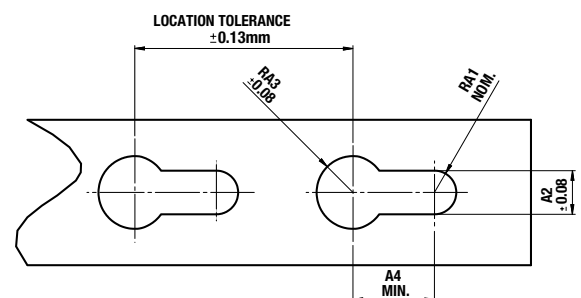

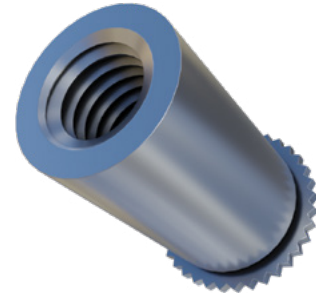
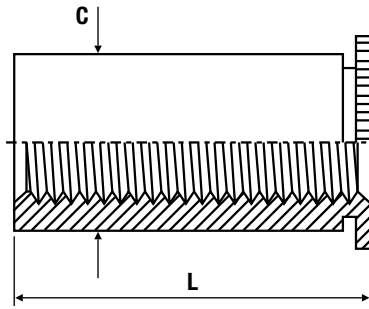
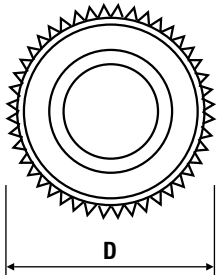

Metric Dimensions

Zinc Plated Steel: TR-DSO | Stainless Steel: TR-DSOS

Thread	M3	
(L) Length +0.05 -0.13	6.35	7.0
C max.	4.2	
D nom.	4.92	
Sheet thickness	0.94 - 6.35	
Recommended hole size +0.08	4.2	
Min. distance to edge of sheet	3.2	

Metric Performance Data

Thread	M3
Test sheet material	Steel
Installation (kN)	5.85
Push-out (N)	334
Torque-out (Nm)	1.2

TR-DSO - Recommended for use in sheet hardness: HRB 80 or less
 TR-DSOS - Recommended for use in sheet hardness: HRB 70 or less

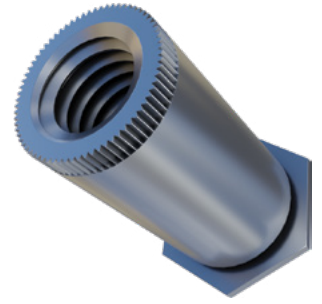
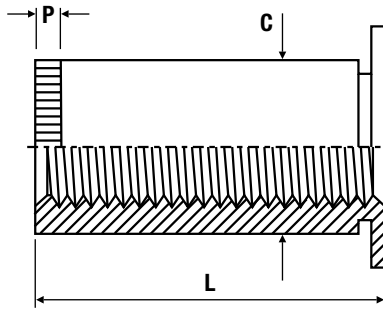
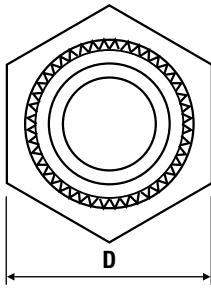

Metric Dimensions

Stainless Steel: TR-SOSG

Thread	M3					
C ± 0.13	5.39					
D nom.	6.4					
Min. sheet thickness	1.0					
P knurling	0.76					
Recommended hole size +0.08	5.4					
Min. distance to edge of sheet	6.8					

Length (L) ±0.13	3	4	6	8	10	12
------------------	---	---	---	---	----	----

TR-SOSG - Recommended for use in sheet hardness: HRB 70 or less

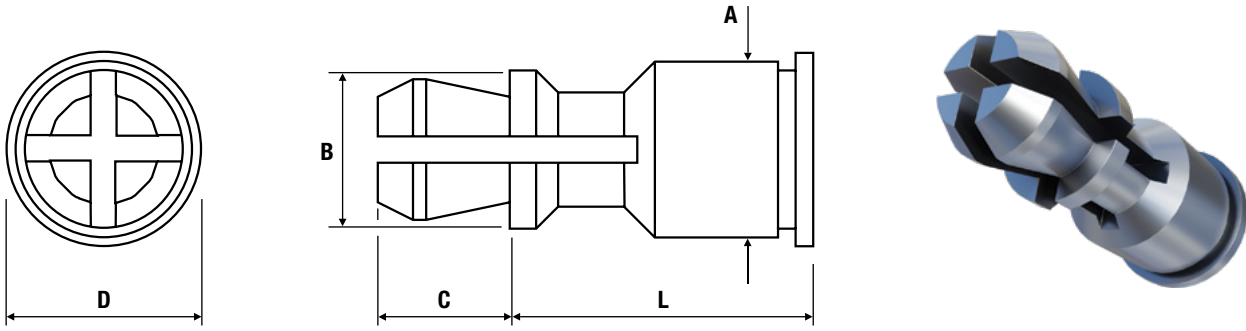

Metric Dimensions

Zinc Plated Steel: TR-SSS | Stainless Steel: TR-SSC | Aluminium: TR-SSA

Top panel mounting hole diameter	4mm
A max.	5.39
B ± 0.13	4.78
C ± 0.13	3.58
D ± 0.13	6.35
Recommended hole size +0.08	5.4

Length (L) ± 0.13	8	10	12	14	16	18	20	22	25
-----------------------	---	----	----	----	----	----	----	----	----

Part number	Panel 1 - Metal HRB50					Panel 2 - PCB or metal			
	Bottom mounting hole +0.08	Max. hardness	Min. thickness	Min. distance to edge of sheet	Max. location tolerance	Top mounting hole +0.08	Max. hardness	Thickness range	Min. distance to edge of sheet
TR-SSS	5.41	HRB 60	1.0	6.6	± 0.13	4.0	No limit	1-1.8	2.54
TR-SSC		HRB 70							
TR-SSA		HRB 50							

Metric Performance Data

Type	TR-SSS	TR-SSC	TR-SSA
Test sheet material	Steel	Steel	Aluminium
Installation (kN)	15.6	16.5	6.7
Push-out (N)	1785	1785	880

TR-SSS - Recommended for use in sheet hardness: HRB 60 or less
 TR-SSC - Recommended for use in sheet hardness: HRB 70 or less

TR-SSA - Recommended for use in sheet hardness: HRB 50 or less

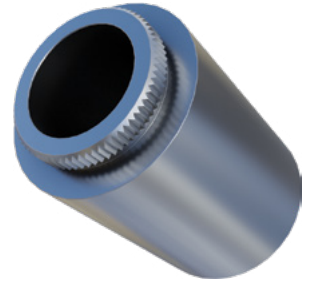
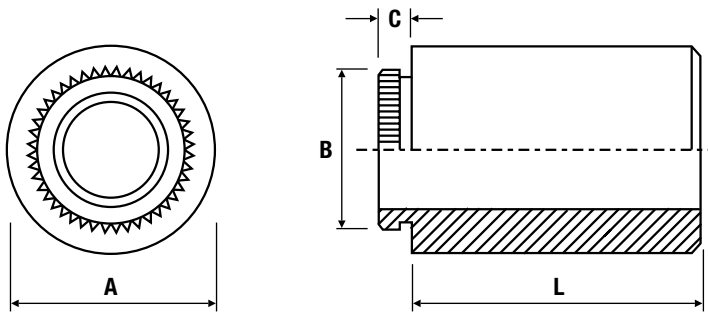

Metric Dimensions

Electro Tin Plated Steel: TR-KFE | Stainless Steel: TR-KFSE

Through hole size	3.6	4.2
A ± 0.13	7.14	8.74
B ± 0.08	5.87	6.86
C max.	1.53	1.53
Min. sheet thickness	1.53	1.53
Recommended hole size +0.08	5.41	6.4
Min. distance to edge of sheet	5.5	7.1

Length (L) ± 0.13	3	4	5	6	8	10	12	14

Metric Performance Data

Through hole size	3.6	4.2
Test sheet material	FR4 fibreglass	
Installation (kN)	2.2	2.2
Push-out (N)	330	420

TR-KFE - Recommended for use in sheet hardness: HRB 60 or less
 TR-KFSE - Recommended for use in sheet hardness: HRB 70 or less

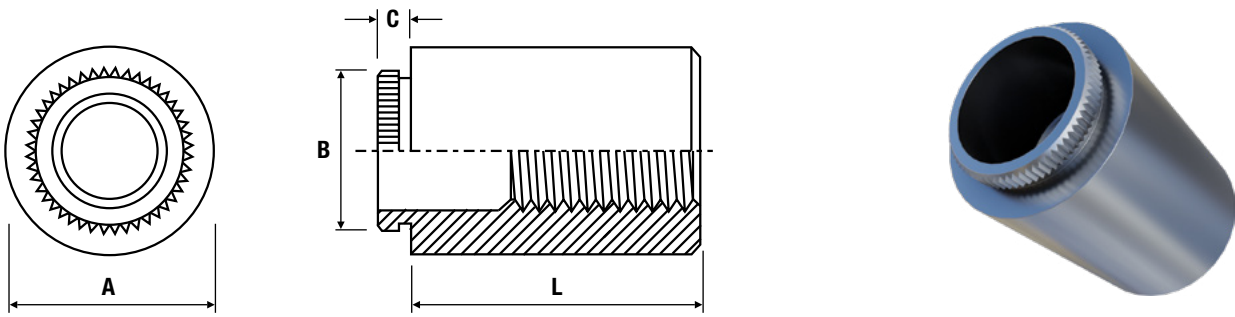

Metric Dimensions

Electro Tin Plated Steel: TR-KFE | Stainless Steel: TR-KFSE

Thread	M3	M4
A ± 0.13	5.56	8.74
B ± 0.08	4.68	6.75
C max.	1.53	1.53
Min. sheet thickness	1.53	1.53
Recommended hole size +0.08	4.22	6.4
Min. distance to edge of sheet	4.4	6.4

Length (L) ± 0.13	3	4	5	6	8	10	12	14	16

Metric Performance Data

Thread	M3	M4
Test sheet material	FR4 fibreglass	
Installation (kN)	2.2	2.2
Torque-out (Nm)	1.4	3.0
Push-out (N)	290	400

TR-KFE - Recommended for use in sheet hardness: HRB 60 or less
 TR-KFSE - Recommended for use in sheet hardness: HRB 70 or less

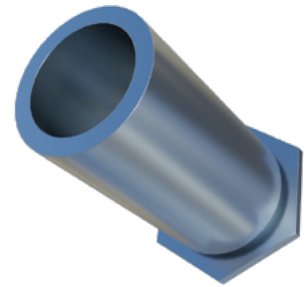
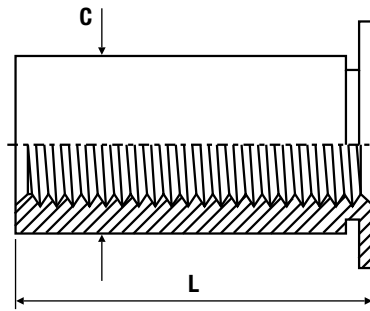
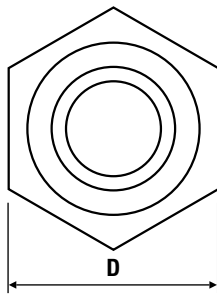

Metric Dimensions

Zinc Plated Steel: TR-TSO | Stainless Steel: TR-TSOS

Thread	M2.5	M2.5 Alt	M3	M3 Alt	M3.5
C -0.13	4.2	5.39	4.2	5.39	5.39
D ±0.25	4.8	6.4	4.8	6.4	6.4
Min. sheet thickness	0.63				
Recommended hole size +0.08	4.22 - 4.30	5.41 - 5.49	4.22 - 4.30	5.41 - 5.49	5.41 - 5.49
Min. distance to edge of sheet	5.8	7.1	5.8	7.1	7.1

Length (L) ±0.13	2	3	4	6	8	10	12	14	16	18	19

Metric Performance Data

Thread	M2.5	M2.5 Alt	M3	M3 Alt	M3.5
Test sheet material	Steel				
Installation (kN)	8.9	11.1	8.9	11.1	11.1
Torque-out (Nm)	1.0	1.7	1.0	1.7	1.7
Push-out (N)	445	667	445	667	667

TR-TSO - Recommended for use in sheet hardness: HRB 60 or less

TR-TSOS - Recommended for use in sheet hardness: HRB 70 or less

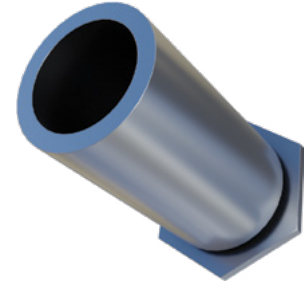
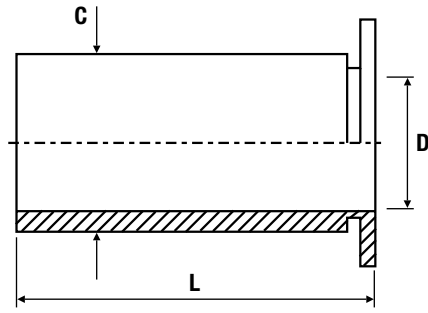
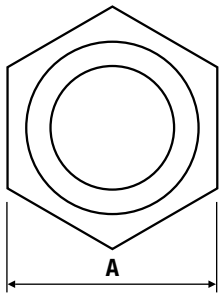

Metric Dimensions

Zinc Plated Steel: TR-SO

Diameter code	43.1	63.1	63.6	83.6	84.1	85.1
D counter-bore diameter -0.13	3.1	3.1	3.6	3.6	4.1	5.1
C -0.13	4.2	5.39	5.39	7.12	7.12	7.12
A nom.	4.8	6.4	6.4	7.9	7.9	7.9
Min. sheet thickness	1.0	1.0	1.0	1.27	1.27	1.27
Recommended hole size +0.08	4.22	5.41	5.41	7.14	7.14	7.14
Min. distance to edge of sheet	6.0	6.8	6.8	8.0	8.0	8.0

Length (L) +0.05/-0.13	3	4	5	6	8	10	12	14	16	18	20

TR-SO - Recommended for use in sheet hardness: HRB 80 or less

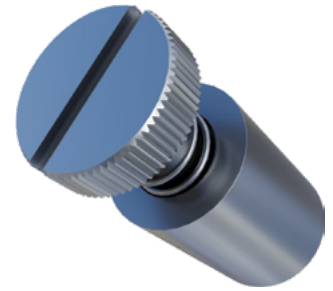
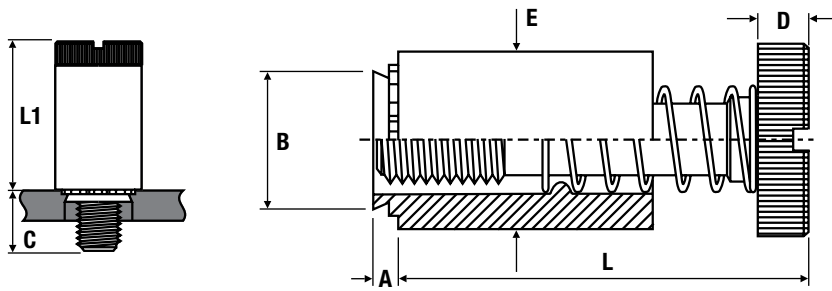

Metric Dimensions

Zinc Plated Steel: TR-PFS2 | Stainless Steel: TR-PFC2

Thread	M3		M4			M5			M6		
Screw length code	40	62	50	72	94	50	72	94	60	82	04
A max.	1.53		1.53			1.53			1.53		
B max.	6.71		7.9			8.72			10.47		
C ±0.4	6.4	9.5	7.9	11.1	14.3	7.9	11.1	14.3	9.5	12.7	15.9
D ±0.13	1.83		2.08			2.08			2.46		
E ±0.25	7.92		9.53			10.31			11.89		
L nom.	13.72		17.53			17.53			22.35		
L1 max.	9.14		11.43			11.47			14.73		
Min. sheet thickness	1.53		1.53			1.53			1.53		
Recommended hole size +0.08	6.73		7.90			8.74			10.49		
Screw protrusion before installation ±0.64	0	3.2	0	3.2	6.4	0	3.2	6.4	0	3.2	6.4
Min. distance to edge of sheet	6.35		7.87			8.63			9.65		

Metric Performance Data

Thread	M3		M4			M5			M6		
Test sheet material	Steel										
Installation (kN)	13.4		17.0			17.9			22.3		
Push-out (N)	1335		1780			2230			2670		

TR-PFS2 - Recommended for use in sheet hardness: HRB 80 or less

TR-PFC2 - Recommended for use in sheet hardness: HRB 70 or less

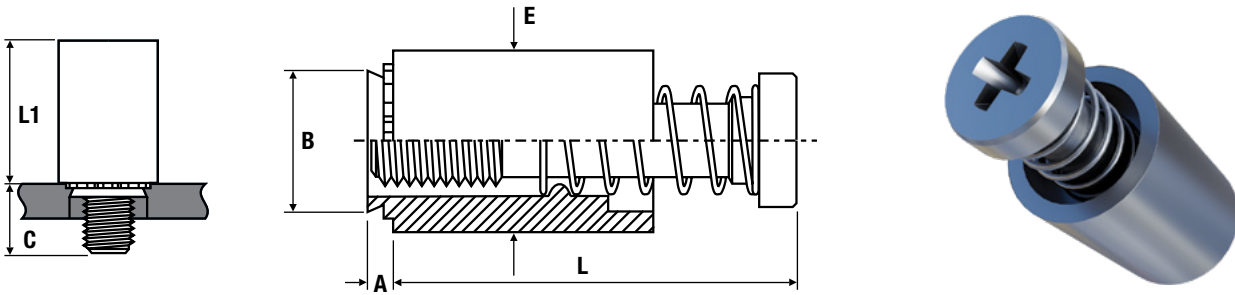

Metric Dimensions

Stainless Steel: TR-PFC2P

Thread	M3		M4			M5			M6		
Screw length code	40	62	50	72	94	50	72	94	60	82	04
A max.	1.53		1.53			1.53			1.53		
B max.	6.71		7.9			8.72			10.47		
C ±0.4	6.4	9.5	7.9	11.1	14.3	7.9	11.1	14.3	9.5	12.7	15.9
Driver size	PH1		PH2			PH2			PH3		
E ±0.25	7.92		9.53			10.31			11.89		
L nom.	13.72		17.91			17.91			22.99		
L1 max.	9.4		12.19			12.45			15.75		
Min. sheet thickness	1.53		1.53			1.53			1.53		
Recommended hole size +0.08	6.73		7.92			8.74			10.49		
Screw protrusion before installation ±0.64	0	3.2	0	3.2	6.4	0	3.2	6.4	0	3.2	6.4
Min. distance to edge of sheet	6.35		7.87			8.63			9.65		

Metric Performance Data

Thread	M3	M4	M5	M6
Test sheet material	Steel			
Installation (kN)	13.4	17.0	17.9	22.3
Push-out (N)	1335	1780	2230	2670

TR-PFC2P - Recommended for use in sheet hardness: HRB 70 or less

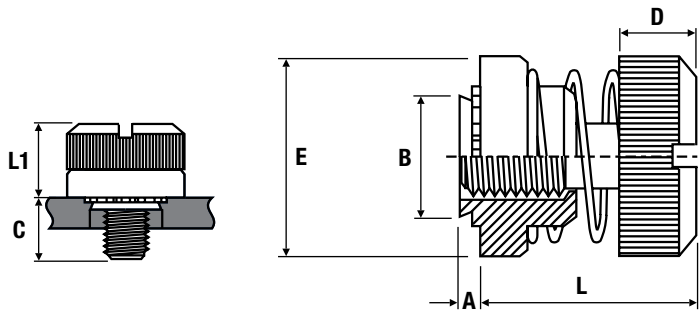

Metric Dimensions

Nickel Plated Steel: TR-PF31 | Nickel Plated Steel: TR-PF32

Thread	M3		M4		M5		M6
Type	TR-PF31	TR-PF32	TR-PF31	TR-PF32	TR-PF31	TR-PF32	TR-PF32
Screw length code	30		30		30		35
A max.	0.97	1.48	0.97	1.48	0.97	1.48	1.48
Min. sheet thickness	1.0	1.5	1.0	1.5	1.0	1.5	1.5
Recommended hole size +0.08	5.5		6.4		8.0		9.5
B max.	5.48		6.38		7.98		9.48
L nom.	15.11		15.24		15.37		17.15
D ±0.13	5.13		5.26		5.59		6.12
E ±0.25	10.31		11.89		13.46		15.88
C ±0.4	7.62		7.62		7.62		8.89
L1 max.	8.26		8.38		8.51		9.78
Min. distance to edge of sheet	6.6		7.37		8.38		9.65

Metric Performance Data

Thread	M3	M4	M5	M6
Test sheet material	Aluminium			
Installation (kN)	9.9	12.6	15.6	19.2

TR-PF31 - Recommended for use in sheet hardness: HRB 60 or less

TR-PF32 - Recommended for use in sheet hardness: HRB 60 or less

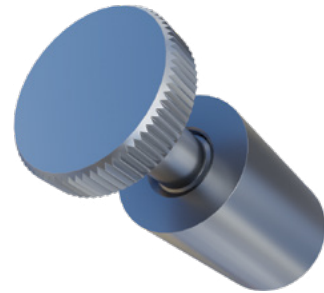
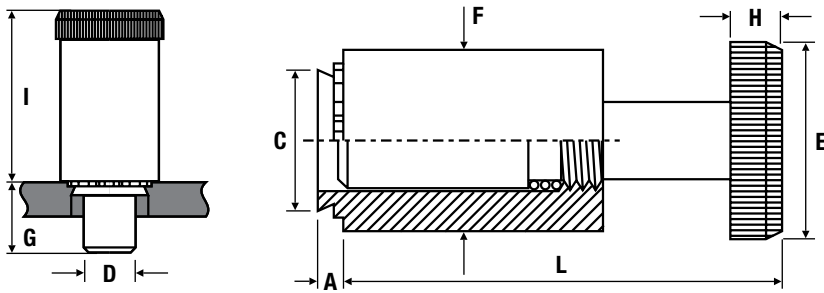

Metric Dimensions

Zinc Plated Steel: TR-PTL2 | TR-PSL2

Type	TR-PTL2 (locking)	TR-PSL2 (non-locking)
Plunger diameter code	04	04
Plunger length code	4.0	4.0
A max.	1.47	1.47
Min. sheet thickness	1.53	1.53
Recommended hole size +0.08	8.33	8.33
C max.	8.31	8.31
D -0.13	6.35	6.35
E ±0.25	12.7	12.7
F ±0.25	10.3	10.3
G ±0.25	7.87	7.87
H ±0.25	4.32	4.32
I ±0.25	15.11	12.95
L nom.	22.73	19.81
Min. distance to edge of sheet	8.64	8.64

Metric Performance Data

Type	TR-PTL2 (locking)	TR-PSL2 (non-locking)
Test sheet material	Steel	
Installation (kN)	17.8	17.8
Push-out (N)	2224	2224

TR-PTL2 - Recommended for use in sheet hardness: HRB 80 or less

TR-PSL2 - Recommended for use in sheet hardness: HRB 80 or less

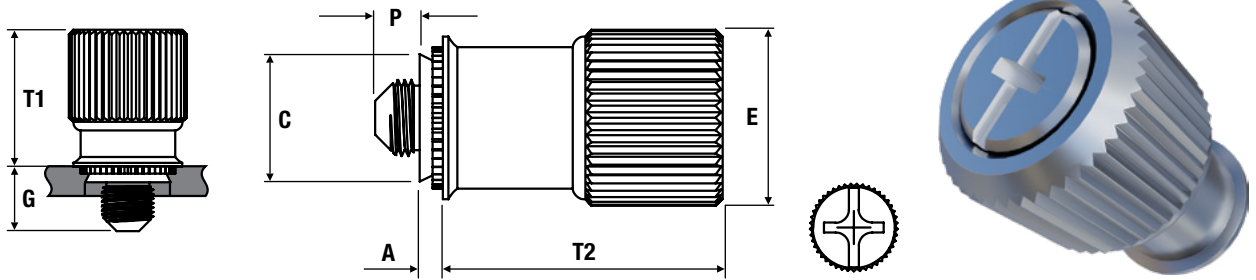

Metric Dimensions

Nickel Plated Heat Treated Steel (Retainer), Aluminium (Knob), Stainless Steel (Screw & Spring): TR-PF11

Thread	M3			M4			M5			M6
Screw length code	0	1	2	0	1	2	0	1	2	2
A max.	0.92			0.92			0.92			0.92
Min. sheet thickness	0.92			0.92			0.92			0.92
Recommended hole size +0.08	5.56			7.92			7.92			9.53
C max.	5.54			7.90			7.90			9.50
E ±0.25	10.59			13.06			13.06			14.61
G ±0.64	4.32	5.84	7.37	5.84	7.37	8.89	5.84	7.37	8.89	10.41
P ±0.64	0	1.52	3.05	0	1.52	3.05	0	1.52	3.05	3.05
T1 nom.	7.87			11.43			11.43			13.46
T2 nom.	11.43			16.26			16.26			20.07
Driver size	PH1			PH2			PH2			PH3
Min. distance to edge of sheet	7.11			8.38			8.38			11.68

Metric Performance Data

Thread	M3	M4	M5	M6
Test sheet material	Steel			
Installation (kN)	11.1	20.0	20.0	22.2
Push-out (N)	645	710	710	865

TR-PF11 - Recommended for use in sheet hardness: HRB 80 or less

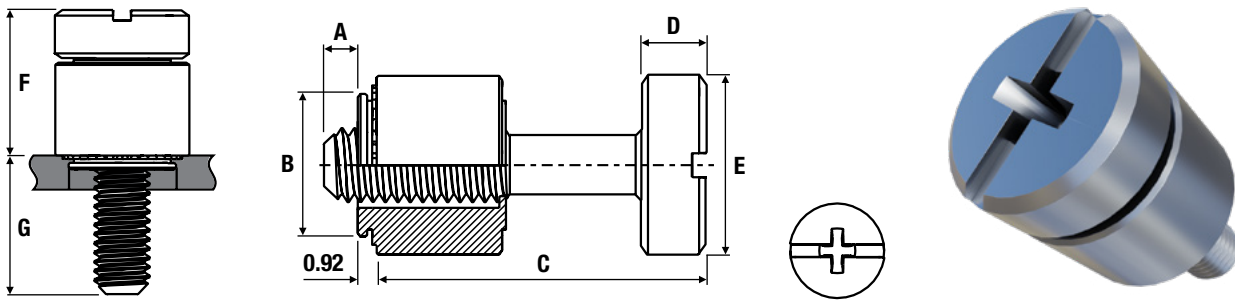

Metric Dimensions

Zinc Plated Steel: TR-PFHV

Thread	M3		M3.5		M4	
Screw code	0	1	0	1	0	1
A (shank) max.	0	1.9	0	2.30	0	2.7
B max.	5.49		5.98		6.38	
C nom.	11.25		12.47		14.1	
D ± 0.13	2.03		2.34		2.79	
E ± 0.25	6.95		7.45		7.85	
F nom.	6.69		7.45		8.5	
G ± 0.64	5.55	7.56	6.01	8.42	6.59	9.39
Min. sheet thickness	0.92		0.92		0.92	
Recommended hole size $+0.08$	5.5 - 5.58		6.0 - 6.08		6.4 - 6.48	
Min. distance to edge of sheet	5.8		6.3		6.7	

Metric Performance Data

Thread	M3	M3.5	M4
Test sheet material	Steel		
Installation (kN)	10.5	11.4	12.1
Push-out (N)	564	614	656

TR-PFHV - Recommended for use in sheet hardness: HRB 60 or less

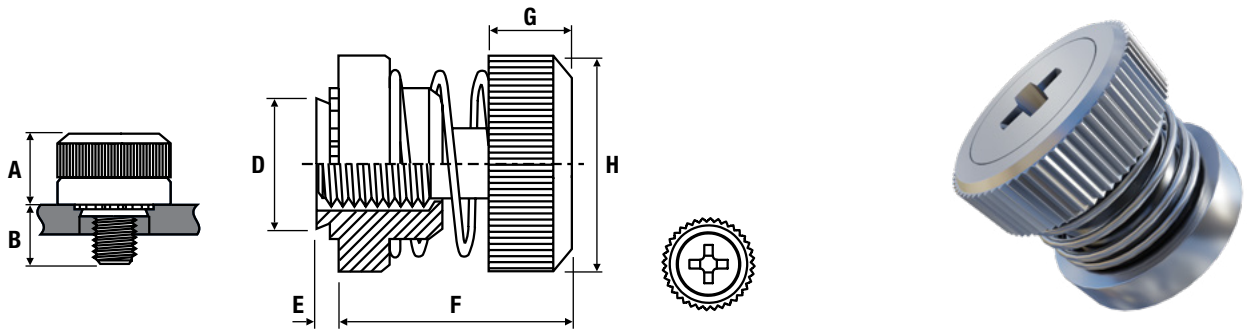

Metric Dimensions

Zinc Plated Steel: TR-PF50

Thread	M3		M4		M5	
	0	1	0	1	0	1
A max.	8.64		8.64		9.15	
B ±0.64	5.84	7.37	5.84	7.37	5.84	7.37
C min. sheet thickness	0.8		0.8		0.8	
D max.	5.48		6.38		7.98	
E +0.4 / -0.13	0.77		0.77		0.77	
F nom.	13.21		13.46		13.46	
G ±0.2	5.26		5.51		5.72	
H +0.4 / -0.13	10.3		11.9		13.5	
Recommended hole size +0.08	5.5 - 5.58		6.4 - 6.48		8 - 8.08	
Min. distance to edge of sheet	6.6		7.4		8.4	

Metric Performance Data

Thread	M3	M4	M5
Test sheet material	Steel		
Installation (kN)	22.2	26.7	35.6
Push-out (N)	400	400	423

TR-PF50 - Recommended for use in sheet hardness: HRB 60 or less

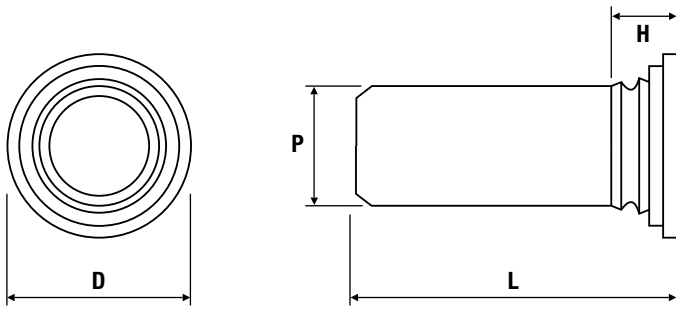

Metric Dimensions

Zinc Plated Steel: TR-TP | Stainless Steel: TR-TPS | 400 Series Stainless Steel: TR-TP4

P pin diameter ± 0.05	3	4	5	6
Min. sheet thickness	1.0			
Recommended hole size	3.5	4.5	5.5	6.5
D ± 0.4	5.20	6.12	7.19	8.13
H max.	2.29	2.29	2.29	2.29
Min. distance to edge of sheet	6.4	7.1	7.61	7.9

Length (L) ± 0.4	3	4	6	8	10	12	16	20

Metric Performance Data

P pin diameter ± 0.05	3	4	5	6
Test sheet material	Steel			
Installation (kN)	23	27	35	40
Push-out (kN)	1	1.6	1.8	2.2

TR-TP - Recommended for use in sheet hardness: HRB 80 or less
 TR-TPS - Recommended for use in sheet hardness: HRB 70 or less

TR-TP4 - Recommended for use in sheet hardness: HRB 92 or less

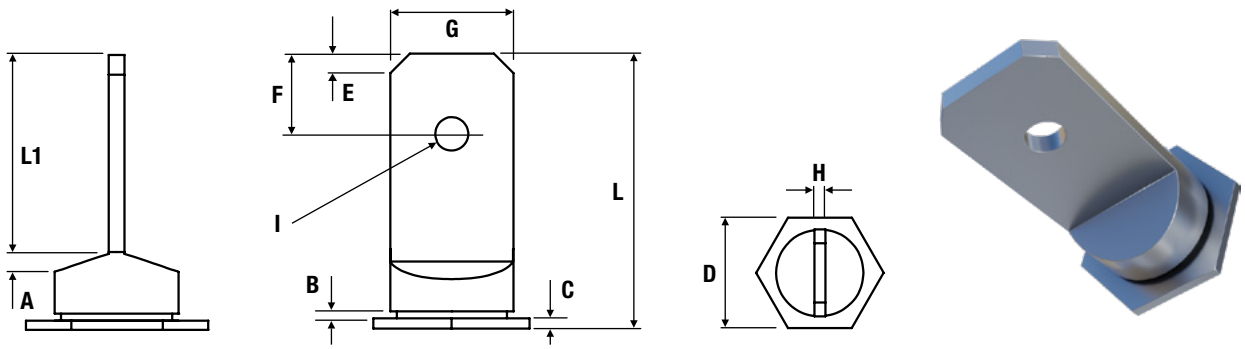

Metric Dimensions

Electro Tin Plated Steel: TR-TER

Part number	TR-TER
A	1.05
B	0.36
C	0.52
D	8.00
E	1 x 45°
F	4.10
G	6.30
H	0.80
I	1.7 dia.
L	14.00
L1	9.00
Plate G x H	6.3 x 0.8
Recommended hole size ± 0.08	6.40
Min. distance to edge of sheet	7.30
Min. sheet thickness	0.80

TR-TER - Recommended for use in sheet hardness: HRB 80 or less

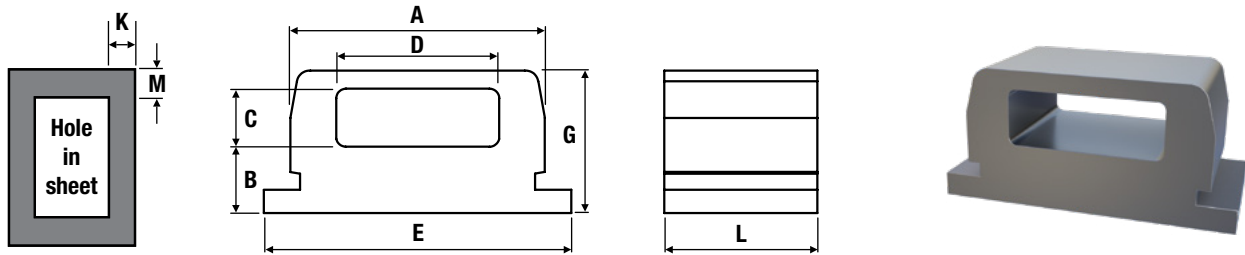

Metric Dimensions

Stainless Steel: TR-TD

Type	TD - 40	TD - 60	TD - 175
Length code	4	6	12
L ±0.08	3.07	4.67	9.42
Sheet thickness	1.02 - 1.27	1.02 - 1.78	1.02 - 3.18
Hole size in sheet +0.05 -0.03	6.35 x 3.18	7.93 x 4.75	12.70 x 9.53
A ±0.08	6.25	7.82	12.60
B ±0.15	1.40	1.91	3.30
C ±0.15	1.65	1.65	2.40
D ±0.15	4.06	5.21	9.14
E ±0.15	7.82	9.40	14.28
Height G ±0.15	3.81	4.57	7.24
Min. hole edge - sheet edge (M)	1.02		
Min. hole edge - sheet edge (K)	3.73	4.98	6.65

Metric Performance Data

Part number	TR-TD-40-4	TR-TD-60-6	TR-TD-175-12
Test sheet material	Steel		
Installation (kN)	8	11	17.7
Push-out (kN)	780	1160	1560
Pull through (N)	445	712	780
Side load (N)	400	445	620

TR-TD - Recommended for use in sheet hardness: HRB 60 or less

Where we operate

Key:

- Head office Trifast plc
- TR Asia headquarters
- Manufacturing, sales & distribution
- Sales & distribution
- Sales office
- Engineering & innovation centre
- Joint Venture (manufacturing)

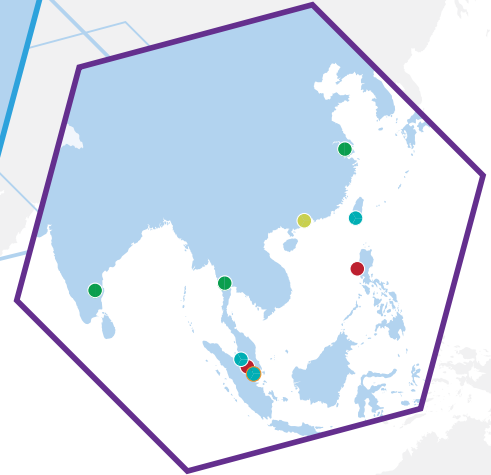
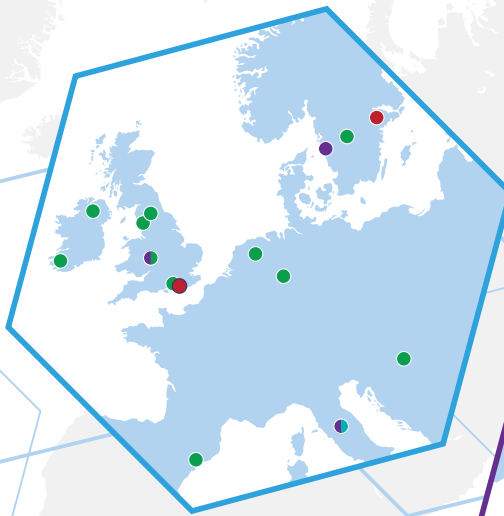
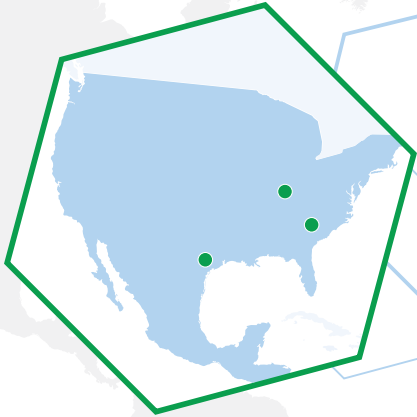

UK

t: +44 (0)8454 811 800
e-mail: uk@trfastenings.com

Ireland

t: +353 (0)22 22301
e-mail: ireland@trfastenings.com

Netherlands

t: +31 (0)541 511515
e-mail: netherlands@trfastenings.com

Sweden

t: +46 (0)8 578 44 900
e-mail: sweden@trfastenings.com

Spain

t: +34 93 647 22 45
e-mail: spain@trfastenings.com

Hungary

t: +36 30 342 1218
e-mail: hungary@trfastenings.com

Poland - Representative

t: +48 (22)402 36 14
e-mail: poland@trfastenings.com

Italy

t: +39 (0)75 9149015
e-mail: info@trvic.it

Germany

t: +49 (0) 5246 . 50320 - 0
e-mail: info@trkuhlmann.com

USA

Houston - t: +1 800-280-2181
Charlotte - t: +1 704-588-4740
e-mail: usa@trfastenings.com

Singapore

t: +65 6759 6033
e-mail: singapore@trfastenings.com

Japan - Representative

t: +86(0)21 5032 6559
e-mail: wudeqing@trformac.com.cn

Malaysia

t: +6 (03) 5519 1444
e-mail: psep@psep.com.my

China

t: +86 21 5032 5696
e-mail: china@trfastenings.com

Taiwan

t: +886 7 557 6366
e-mail: taiwan@trfastenings.com

Philippines - Representative Office

t: +63-25768476
e-mail: philippines@trfastenings.com

India

t: +91 (0)44 4280 3932
e-mail: india@trfastenings.com

Thailand

t: +66(0)2 130 6562
e-mail: thailand@trfastenings.com



Engineering & innovation centres

Birmingham - UK

t: +44 (0)121 521 0000
e-mail: engineering@trfastenings.com

Gothenburg - Sweden

t: +46 (0)31 31 760 776
e-mail: engineering@trfastenings.com

Italy

t: +39 (0)75 9149015
e-mail: engineering@trfastenings.com



Master Distributor Details

